

# **TALEGA MAINTENANCE CORPORATION ARCHITECTURAL GUIDELINES**

**DESIGN STANDARDS, PROCEDURES, RULES AND  
GUIDELINES ARE CONTAINED WITHIN**

Originally Approved: July 2000

Revised: 07/2023

Updated: 05/2024

Reformatted: 07/2025

Updated: 10/2025

**Architectural Review Process & Application Basics**

Glossary of Terms	6
Architectural Guidelines Purpose	8
General Conditions	9
Application Process	11
Drawings and Specifications	11
Other Information	11
Request to Revise Approved Plans	12
Notice of Completion	12
About the Review Process	13
Failure to Comply	13
Resubmittal Requirements	13
Final Approval	14
After the Review Process	14
Appeal Procedure	15

**Additional Information**

Right to Adopt Additional Architectural Guidelines	15
Failure to Obtain Written Approval for Improvements	15

**General Architectural Standards**

Construction and Contractor Rules and Hours of Operation	16
Maximum Heights	17
Setbacks	17
Exterior Stairs	17
Roofing & Skylights	17
Exterior Building Walls	17
Solar Energy Systems	18
Reflective Finishes	19
Basketball Backboards	19
Skate Ramps	19
Sporting Equipment	19
Shade Structures & Awnings	20
Deck / Balcony	22
Playhouses / Play Structures / Trampolines	22

Sundecks	23
Additions / Casitas / Remodels / Exterior Modification	23
Garage Conversions	24
Garage Doors	25
Temporary Buildings/Sheds	25
Barbeque/Bar Structures	25
Fireplaces and Fire Pits	25
Air Conditioners	25

### **General Landscape Standards**

Landscaping / Hardscape	25
Creating Visual Barriers or Privacy Screens Is Not Permitted	26
Restrictions	26
Thematic Items, Fountains, and Statuary	27
Pools, Spas and Rockwork	28
Walls, Fences and Gates	29
Alternative Fences and Gates	31
Drainage	31
Parkway Street Trees	31
Artificial Turf	32
Paved Areas	33
Driveways, Aprons and Walkways	33
Lava Rock and Decorative Rock	34

### **Miscellaneous**

Exterior Painting	34
Exterior Lighting	35
Under Eave Lighting	35
Holiday Lighting	35
Flagpoles	36
Clotheslines & Drying Racks — Backyards Only	36
Windows and Doors	36
Window Coverings	36
Line of Sight	37
View Obstructions	37
Surveillance Cameras	37

**Pre-Approved Items**

Pre-Approved Sustainable Parkway Modifications Plan for each Neighborhood in Talega	37
Wrought Iron Fencing Attachment Material to Control Access of Critters	38
Rain Gutters and Downspouts	38
Screen Doors	38
Personal Agriculture	38
Satellite Dishes and Antennae	38
Address Font Style	39

**Policies**

Submittal of Home Improvement Application Prior to COE Policy	39
Neighbor Dispute Policy	40
Drainage Policy	41

**Important Architectural Requirements for Sub-Associations**

Special Requirements For Trinidad	43
Special Requirements For Carmel	43
Special Requirements For Verano	44
Special Requirements For Talega Gallery	46

**Other Documents and Information**

Exhibit D-1 ~ D-5 Talega Plant, Tree, Shrub and Ground Cover Palette	47
Exhibit D-6 Prohibited Plant and Tree Species	52
Exhibit D-7 Plants Recommended for Fuel Modification Zones	53
Exhibit E-6 Setback for Outdoor Fireplace	54
Exhibit F Sample Planting Plan	55
Exhibit G-1 6' Slump Block Wall	56
Exhibit G-2 Tubular Steel Atop Low Slump Block Wall	57
Exhibit G-3 Talega Approved Tubular Steel Gates	58
Exhibit G-4 Talega Approved Wood Gates	59
Exhibit H Master Paint Schemes	Request from Management
Exhibit I Sustainable Parkway Plans by Neighborhood	Request from Management

**TALEGA MAINTENANCE CORPORATION CC&RS — ARCHITECTURAL CONTROL****REFERENCES:**

**1.3 Definition of Architectural Guidelines:** Architectural Guidelines are the design standards, procedures, rules and guidelines.

**3.1 Members of Committee:** The Design Review Committee has the right and duty to promulgate Architectural Guidelines against which to examine any request made pursuant to this Article.

**3.2.2 Issuance of Architectural Guidelines:** The Design Review Committee maintains it has the right to issue and regularly update its Architectural Guidelines and will submit to the Board of Directors for review, comment and approval.

**3.4.1 Improvements Requiring Approval:** No construction, installation or alteration of an Improvement, included in our guidelines, within the Properties by an Owner or a Sub-association may be commenced until the plans and specifications therefore showing the nature, kind, shape, height, width, color, materials and location thereof have been submitted to and approved in writing by the Design Review Committee.

**3.4.3 Standards for Approval:** The Design Review Committee shall approve plans and specifications submitted only if it determines that (a) the installation, construction or alteration contemplated thereby in the locations indicated will not be detrimental to the appearance of the surrounding area of the Properties as a whole, (b) the appearance of any structure affected thereby will be in harmony with the surrounding structures, (c) the installation, construction or alteration will not detract from the beauty, wholesomeness and attractiveness of the Corporation Property or the enjoyment for the Members, and if applicable, (d) the maintenance of the development will not become a burden on the Master Association.

**3.6 No Waiver of Future Approvals:** The Design Review Committee's approval of any proposals, plans and specifications or drawings for any work done, proposed or in connection with any matter requiring the Design Review Committee's approval does not waive the right to withhold approval of any similar proposals, plans, specifications, drawings or matters subsequently submitted for approval.

**GLOSSARY:**

**Adjacent Neighbor:** All neighbors with adjoining property lines to the applicant.

**Attached Home:** All duplex, triplex, fourplex, or multi-family type homes.

**ADU:** Accessory Dwelling Unit a secondary dwelling unit with complete independent living facilities for one or more persons and takes two forms: Detached: The unit is separated from the primary residential structure. Attached: The unit is attached to the primary residential structure.

**Common Area:** Parts of the community or complex owned and maintained by the HOA and intended for all residents' use. Common areas may include things like parks, pools, parking lots, and landscaping. The HOA is responsible for maintaining and repairing these areas, and residents are expected to follow the rules and regulations in place for their use.

**Covenants, Conditions & Restrictions (CC&R's):** Recorded covenants, conditions and restrictions and property limitations of a common interest development. & Restrictions

**Development:** Shall mean and refer to the Covered Property and the Annexation Property as defined in the CC&R's.

**Double Fencing:** A security method that involves building two fences parallel and side-by-side with a space between them. That includes any type of fence extension atop the existing.

**Drought Tolerant:** A plant adapted to surviving with little water.

**Impacted Neighbor:** All neighbors, in the immediate surrounding area, whose use and enjoyment of their property would be impacted by the construction of any proposed improvement.

**Kelvins:** Also known as the color temperature, it is a measurement of the color of light produced by a light source. It is typically indicated by a number followed by "K". Lower Kelvin values indicate warmer, more yellow or orange light, while higher Kelvin values indicate cooler, more blue or white light.

**Like-for-Like:** Replacing a damaged or worn-out component of a property with a replacement component that is identical or equivalent in terms of its design, materials, and functionality. For example, if a fence panel in a common area of an HOA is damaged, the HOA may replace it with a new fence panel that matches the design and materials of the original fence panel, rather than replacing it with a different type of fence panel that does not match the existing fence.

**Lumens:** A measure of the amount of light emitted by a light source. The higher the number of lumens, the brighter the light. Essentially, lumens measure the brightness of a light bulb or other light-emitting device.

**Organic Mulch:** A type of mulch made from natural materials that are derived from living organisms, such as leaves, grass clippings, bark, straw, and compost. Organic mulch is used in gardening and landscaping as a layer of material spread over the soil to help retain moisture, regulate soil temperature, suppress weed growth, and improve soil health. As organic mulch breaks down over time, it releases nutrients back into the soil, providing a natural fertilizing effect.

**Over the Counter:** Any architectural applications reviewed by Management at TMC instead of the Design Review Committee. These reviews typically do not charge a fee for review and have a quick turnaround time.

**Privacy Screening/Visual Barrier:** The installation of a barrier, such as a hedge or trees, to create privacy or a homeowner's property from neighboring properties or shared common areas.

**Retrofitted Windows:** The process of installing new windows into an existing window frame or opening, without removing the entire frame. This allows for the replacement of old, inefficient windows with new ones, without the need for extensive renovation or reconstruction work. The new windows are fitted into the existing frame, which is often a cost-effective solution for homeowners who want to improve energy efficiency, noise reduction, or simply upgrade the look of their home.

**Return Wall:** A type of wall that is perpendicular to the main wall and connects it to another surface or structure. It is commonly used in building construction to provide additional support and stability to the main wall. Return walls can also help to define the boundaries of a room or space and may be used to create corners or other architectural features. In the community, you see them connected to side gates quite frequently.

**Site Plan:** A scaled drawing showing the subject site (or lot), its property lines, buildings or any other improvements, proposed modifications, and a portion of adjacent properties with adequate dimensions to clearly describe the property or intent of property.

**Softscape:** Vegetation (such as shrubs and flowers) that is incorporated into a landscape.

**Topsoil:** The uppermost layer of soil on the earth's surface, containing a mixture of organic and inorganic materials. It is important for growing plants because they contain nutrients and microorganisms that plants need to thrive. Topsoil is typically found in the top 2-8 inches (5-20 cm) of the earth's surface and is used in gardening and landscaping as a nutrient-rich layer for planting.

**Wattage:** Is a measure of how much electrical power is used by an appliance or device. It is typically represented by the symbol "W" and is a measure of the rate of energy consumption.

**PURPOSE**

The purpose of these Architectural Guidelines is to preserve and improve the physical character as established by the initial development of the community of Talega. The intent is to give specific design criteria to Owners for subsequent improvements after the completion of original construction. The Design Review Committee will generally require owners to comply with the Architectural Guidelines. However, depending upon circumstances, the Design Review Committee may approve an owner's proposal that does not strictly conform to those Guidelines if the Design Review Committee determines that the purposes of the Guidelines would still be achieved in a particular instance without requiring strict conformance to the Architectural Guidelines.

The Architectural Guidelines are written to preserve a high quality of appearance, to ensure compatibility between improvements, and to enhance the overall value of the community of Talega. They are intended to be used by Owners and consultants in preparing drawings for architectural, landscape, and other improvements; and by the Design Review Committee (DRC) in reviewing these drawings for conformance with the stated objectives. The DRC reviews proposed Improvements for aesthetics purposes only. It is the Owner's responsibility to follow all applicable federal, state and local building codes. Permits may be required by the City of San Clemente and/or County of Orange. By submitting an architectural application to the Design Review Committee, the owner represents and warrants to the Design Review Committee and Talega Maintenance Corporation that the plans and specifications submitted in connection with the application do not violate any governing provisions of the law, including but not limited to, the Fair Employment and Housing Act (California Government Code Section 12900 et seq.), or a building code or other applicable law governing land use or public safety. Owner may also need to acquire approval from the City of San Clemente and / or County of Orange for permission to encroach within city / County easement.

Talega Maintenance Association is comprised of numerous unique housing types unified by a common derivative of a Spanish Colonial village theme. Great care has been taken to create an image of understated elegance throughout the community. Loggias, balconies, recessed windows/thickened walls, window shutters, arbors, decorative iron and stone walls which define an entire building mass are used in the various housing types to give each its individual character. Excessive ornamentation is avoided allowing the building masses, building voids and richly textured materials to provide the sole architectural interest. When modifying or adding to a home, architectural features unique to each community are to be given higher priority for use than features imported from other communities. Roof lines are intentionally broken and varied to create the look and impression of a village. Housing additions which strive to maximize the livable floor area by ignoring the need for broken roof lines and building masses defined by well-placed voids are not permitted. To maintain or enhance architectural massing, recesses, stepped forms and architectural projections are to be used for room additions. Landscape and hardscape which follow the same principles of an understated Spanish Colonial theme and reinforce the architecture of the home are essential to the character of the community. Applicants are required to recognize the unique qualities of the housing and remain within the context of the existing community.

**GENERAL CONDITIONS**

Conditions Not Defined: Any condition or material not defined within these Architectural Guidelines shall become a matter of judgment on the part of the DRC.

1. Talega Maintenance Corporation Design Review Committee (DRC) approval does not constitute waiver of any requirements required by applicable governmental agencies.
2. Members of a Sub association must receive approval from the Sub association prior to submitting plans to TMC.
3. DRC approval of plans does not constitute acceptance of any technical or engineering specifications, and Talega Maintenance Corporation assumes no responsibility for such. The function of the DRC is to review submittals as to aesthetics. All technical and engineering matters are the responsibility of the Owner.
4. Should the DRC inadvertently approve an Improvement which conflicts with a provision of the CC&Rs, Bylaws, Rules and Regulations, Architectural Guidelines, or a Committee policy, it does not constitute waiver of that rule and therefore, must be corrected upon notice.
5. Approved plans are not to be considered authorization to change the drainage plan as installed by the builder and approved by the City of San Clemente and / or County of Orange and / or Talega Joint Planning Authority.
6. City of San Clemente and/or County of Orange and / or Talega Joint Planning Authority ordinances require Owners to maintain correct grades of Lots so that runoff does not flow onto adjoining properties or does not prevent off flow from the same.
7. Access for equipment used in construction must be through your property only. Access over Common Area requires written authorization from the Board of Directors.
8. Streets may not be obstructed with objects and building materials that are hazardous to pedestrians, vehicles, etc. Items such as, but not limited to, sand and building materials may not be stored on streets, sidewalks or Common Area.
9. Any damage to the Common Area will be replaced or repaired by a Talega Maintenance Corporation subcontractor. All applicable charges for restoration will be charged back to the Owner by Talega Maintenance Corporation and will be due and payable within 30 days from notification.
10. Approval of plans is not authorization to proceed with Improvements on any property other than the Lot owned by the applicant.
11. Once an Owner receives approval from the DRC, construction may commence. Upon completion of the approved Improvement(s), a Notice of Completion (Exhibit C-1) must be forwarded to Talega Maintenance Corporation, at the address listed on the front of this form. Any photos required by the DRC will not be returned to the Owner.
12. Each Owner and builder shall be responsible for providing adequate sanitary facilities for their construction workers. Portable toilets or similar temporary toilet facilities shall be located in the lot itself.

13. Property is to be cleaned at least once a day during construction. Debris must be moved from the site, not merely hosed onto the next property. All rubbish and unsightly material or objects of any kind shall be regularly removed from the Lot and will not be allowed to accumulate thereon. Removal shall be made weekly, preferably on Friday and rubbish will not be allowed to accumulate on streets or Common Areas. The Owner will be responsible for the cost of any trash cleanup work performed by the Association. Owners are prohibited from dumping, burying or burning trash anywhere within the Community. Concrete trucks washing out their spill pans before leaving the construction site shall do so only on Owner's lot.
14. All improvements shall be performed in a manner consistent with the existing structures. Any work deemed by the Design Review Committee to be of inferior quality shall be reworked or removed and the building restored to its original condition prior to commencement of the work by the Owner. If the Owner refuses to rework or remove to restore as called for above, the Design Review Committee shall request the Board of Directors to initiate such rework, removal or restoration and the cost thereof shall be a Special Assessment against the Owner as provided in the Declaration.
15. Approval of Improvements by the DRC is for aesthetic purposes only. It is the Owner's responsibility to see that all federal, state, and local ordinances and codes are followed. The City of San Clemente and County of Orange may require permits; however, it is not within the DRC's or TMC's scope of responsibility to confirm the existence or accuracy of permits.

**APPLICATION PROCESS / PLAN SUBMITTAL**

Drawings and Specifications - Plans may be submitted by email. However, physical plans may be required. Applicant reviews the Architectural Guidelines, prepares and submits plans and the application depicting the proposed improvements. Plans that do not contain the following details may be returned incomplete and will require resubmittal. Although not required, the DRC recommends that homeowners retain the services of a design professional for the drawing / submittal preparation. Plans submitted for review shall be drawn at the scales listed below:

Drainage Plan at 1/4" = 1'

Roof Plan at 1/4" = 1'

Floor Plan at 1/4" = 1'

Elevations at 1/8" = 1'

Sections at 1/4" = 1'

Fence and Wall Plans at 1/8" = 1'

**OTHER INFORMATION**

- a. If proposed Improvements require access over the Common Area or Association Property for the purposes of transporting labor or materials, written permission for such access shall be required from Talega Maintenance Corporation, before Association maintained property is accessed or modified. Any such requests must be reported to the DRC prior to the commencement of construction. If permission is granted, a refundable deposit in the amount of \$500 and a completed Indemnification, Repair and Maintenance Agreement is required before work begins. The deposit will be refundable after a visual inspection of the area by a representative of the Talega Maintenance Corporation confirms no additional repairs are required. If access or alteration results in the Association conducting repairs to restore the area, the homeowner may be responsible to reimburse the Association for expenses in addition to forfeiting the deposit.
- b. No Owner shall alter any landscaping, and/or otherwise change any Common Area, owned and maintained by Talega Maintenance Corporation. If an owner changes and/or damages the Common Area, the owner will be invited to a compliance hearing and will be responsible for the cost of the modifications/damages to the Common Area.
- c. Any color changes must be compatible with the neighboring homes and require approval from the DRC. If a variance was offered to a neighboring homeowner for paint or any other improvement(s), that does not guarantee any homeowner will be offered the same variance. All variance requests are reviewed on an individual basis. All paint color changes must be submitted for and approved prior to work commencement.
- d. Common Area walls must not be painted to match the homeowner's home color scheme.
- e. The DRC may require an additional fee for items which require extensive review.
- f. Any other information or documentation which may be deemed necessary by the DRC in reviewing the request.

- g. The DRC approval is based on the completeness and clarity of the drawings. Inadequate or unclear information may cause the DRC to deny the application or deem the application incomplete.
- h. Model Homes and the existence of developer or builder installed improvements/features shall not constitute waiver of the Guidelines, nor act as a precedence for similar items.
- i. The existence of unapproved items or colors on other developments or lots shall not constitute precedence for DRC approval of similar items or colors.
- j. Existence of approved items or colors, as result of a “Variance” or “Exception to the Guidelines”, on other developments or lots shall not constitute precedence for DRC approval of similar items or colors.
- k. The replacement of the builder installed rear/side yard walls/fences and modification of the existing house architecture will be considered on an individual basis. Replacement material or modification shall be consistent with the surrounding tract.

#### **Request to Revise Approved Plans**

This form is available upon request only and is to be used should you need to make changes to your Approved Plans due to unforeseen circumstances during construction.

Often, the Notice of Completion is rejected because the Approved Plans do not match the as-built condition. Sometimes a modification needs to be made for the work to be completed. The intent of the form is to allow you to send in changes to prevent the denial of the Notice of Completion when you are completed with your approved project.

Some examples are listed below:

1. You want to install more drought resistant plant materials or change the type and locations of trees listed on the Approved Plans.
2. You want to install a side yard gate which is a unique design and / or color than the gate on your Approved Plans.
3. An outdoor barbeque is approved on the plans facing the home. During construction, the outdoor Barbeque must be rotated 90 degrees to meet a code or allow for the gas line, etc.

Please contact Management to obtain more information and the appropriate form.

#### **Notice of Completion**

Once an Owner receives approval from the DRC, construction may commence (subject to city / county permit requirements). Upon completion of the approved Improvement(s), a Notice of Completion (NOC) along with photographs of all installed improvements must be emailed to the TMC Design Review Committee at [TALEGA@ciramail.com](mailto:TALEGA@ciramail.com). An on-site Notice of Completion Inspection will then be scheduled and performed by a representative of the DRC prior to the review meeting.

Application for Notice of Completion for Pre-Approved Sustainable Parkway Modification Plan for each Neighborhood in Talega:

Once an Owner has installed the pre-approved sustainable parkway plan and modified irrigation plan an Application for Notice of Completion form must be submitted to the Design Review Committee. Deviations or substitutions to the plant material or hardscape is only allowed on the pre-approved plans if they are drought tolerant plants and will be reviewed on an individual basis.

The parkway street trees are to remain per the supplemental CC&R's, Talega Specific Plan, and the City of San Clemente.

### **ABOUT THE REVIEW PROCESS**

Plans will be reviewed by the TMC Design Review Committee (DRC) once each month. The date and time of the DRC meetings shall be set by the members of the Committee. If the DRC is unable to meet the quorum, it may require the meeting to be moved.

The Design & Review Coordinator will review each Submittal Package for completeness and consistency with the Architectural Guidelines Submittal Requirements. The Design Review Committee will not review incomplete submissions. Incomplete submissions will be returned to the applicant along with a copy of a checklist noting the areas of deficiency. The forty-five (45) day review period for proposed improvements will not commence until a complete submittal has been acknowledged by the Design Review Committee in writing.

The DRC approves or denies the submittal. Approval may be given with conditions. (CC&Rs Article III, Section 3.4.3.)

### **FAILURE TO COMPLY**

Failure to comply with the requirements and procedures set forth herein shall cause the review of your request to be delayed. To avoid delays, please work with your Design & Review Coordinator to ensure you include all required items in your submittal. An incomplete Submittal Package will not be reviewed by the DRC and will be returned to the Owner. If work has commenced prior to approval, there may be potential fines associated for failure to comply with architectural requirements and guidelines.

If a Notice of Completion (NOC) is denied, Owner is responsible for modifying improvements to be consistent with the guidelines and as outlined in the approval letter. Failure to receive NOC approval may result in a violation and potential fines. Owners are responsible for rectifying all outstanding that are not consistent with approved plans within a sixty (60) day period.

### **RESUBMITTAL REQUIREMENTS**

Applicants shall have up to sixty (60) days from the date the denied plans are received in which to re-submit plans when required, due to incompleteness or denial of request. Applicants may submit revised plans by email to [TALEGA@ciramail.com](mailto:TALEGA@ciramail.com) with the property address in the subject line. All re-submissions must reflect all changes and clarifications required by the DRC. Substantial changes to the original design, beyond those previously conditioned by the DRC, may require applicant to submit an additional review fee. Examples of substantial changes include, but are not limited to, additional structures or new features to the original plans.

**FINAL APPROVAL**

Decisions of the Design Review Committee and the reasons therefore shall be transmitted by email or by mail to the Applicant at the address set forth on the Property Improvement Form, within forty-five (45) days after receipt by the DRC of all forms, review fees and materials required by the DRC. No work shall commence on any Improvements without the final written approval of the Design Review Committee.

**AFTER THE REVIEW PROCESS**

Construction must proceed consistently with the approved drawings and the timeline as outlined in the Architectural Guidelines. If revisions are made to the approved plans, owners must submit for these changes to the proposed improvements prior to installation. Failure to submit for these changes / revisions to an improvement may result in the Owners having to remove or modify the improvement solely at the Owner's expense and potential fines through the violation process.

All work must be performed consistent with the Residence's construction standards and with the community's design and appearance. All work considered being of an unsightly finished nature or of lesser quality than the prevailing community standards shall be reworked to an acceptable appearance at Owner's expense.

If work has not commenced after one year following the original approval date, the request and approval will be deemed null & void, and a new request must be submitted to the Design Review Committee (DRC) for review and approval.

Work shall continue in a scheduled manner. If delays are encountered, the Applicant must make a written request for an extension of the approval to the TMC, citing the reasons for the delay and the approximate time for continuing the project. Unless extensions are granted in writing, substantial construction must start within six (6) months and be completed within twelve (12) months. If a project has not commenced within six (6) months after approval, the application becomes null and void and must be resubmitted for approval. Extensions may be granted, if requested in writing to Management. Extensions may be granted for ninety (90) days at the discretion of the Management. Any request for extension to exceed the 90-day period will be reviewed on a discretionary basis by the DRC.

Starting and stopping work for extended periods of time is not permitted. The owner/applicant must prepare the property to protect the surrounding properties from erosion, damage, or unsightly conditions. Such work shall begin immediately upon approval of plans by the Association.

Observation of work in progress and issuance of notices of noncompliance may be made by the Design Review Committee or its designated representatives upon proper notification to the Owner/Applicant. The absence of such observation and notification during construction does not constitute either Design Review Committee approval of the work in progress or compliance with these Guidelines.

After construction is completed, the Owner shall submit a Notice of Completion (NOC) to the DRC within thirty (30) days. An on-site Notice of Completion Inspection will then be scheduled and performed by the Design Review Coordinator or the DRC's designated representative. Observations of completed Improvements may be made by the DRC or its designated representatives once the Owner has notified the DRC with a Notice of Completion. This notification should be made promptly after the Improvement's completion. If it is determined that the work was not done in substantial compliance with the final plan approved by the DRC, the Committee shall notify the Owner in writing of such noncompliance within ten (10) business days after its inspection, specifying in reasonable detail the particulars of noncompliance,

and shall require the Owner to remedy the noncompliance. Failure to rectify a denied NOC may result in potential fines for failure to comply with the architectural guidelines and community character.

### **APPEAL PROCEDURE**

In an event that the plans and specifications submitted to the DRC are disapproved, the applicant making said submission may appeal in writing to the Board of Directors of the Association.

The only Person with the right to appeal an application that has been rejected is the Applicant. "Adjacent Owners" and the Applicant are the only Persons who have the right to appeal any approved application. If an applicant's proposal is disapproved by the DRC, pursuant to California Civil Code Section 4765 and Section 3.12.3 of the CC&Rs, the applicant may appeal the disapproval to TMC's Board of Directors. For the Board of Directors to reconsider the DRC's disapproval of the applicant's proposal, the applicant must submit a Notice of Reconsideration to the Design Review Coordinator no later than the last Friday of the month that the DRC disapproved the proposal by 5:00 p.m. on the tenth business day following the date on which the DRC mailed its disapproval to the applicant. The Notice of Reconsideration must contain a concise description of the reason for the appeal. Within 30 business days following its receipt of the Notice of Reconsideration, the Board of Directors will schedule a reconsideration hearing for the applicant and advise the applicant of the reconsideration hearing date, which date must be no later than 60 calendar days following the board's receipt of the Notice of Reconsideration. At the reconsideration hearing (which must, in accordance with California Civil Code Section 4765 take place at an open meeting of the board), the applicant will have an opportunity to explain to the board why the applicant feels that the DRC's disapproval should be overturned, specifically addressing the reasons the DRC gave for disapproving the proposal. The Board of Directors shall communicate its decision to the applicant in writing no later than 15 calendar days following the reconsideration hearing.

### **ADDITIONAL INFORMATION**

#### **Right To Adopt Additional Architectural Guidelines**

The DRC may sometimes adopt additional, update and/or amend existing standards. Copies of such additions, and/or amendments, will be distributed to the membership and kept on file at Talega Maintenance Corporation.

#### **Failure To Obtain Written Approval for Improvements**

If written approval of the DRC is not obtained, construction shall constitute a violation of the CC&Rs, and the unauthorized improvement may have to be modified or removed at the Owner's expense.

## GENERAL ARCHITECTURAL STANDARDS

### CONSTRUCTION AND CONTRACTOR RULES AND HOURS OF OPERATION

The Owner is to ensure that any contractor / worker they hire to perform work adheres to the following:

1. Contractors / workers shall abide by all posted traffic and safety rules, city ordinances and California Vehicle Code.
2. Vehicles and other equipment must be parked so as not to block traffic or access to fire hydrants, driveways or streets and not parked in marked fire lanes (painted red curbs and/or signed).
3. Contractors / workers must not leave vehicles, equipment, trash, construction debris or material on public and/or private (Association) streets overnight.
4. Each Owner and contractor shall be responsible for providing adequate sanitary facilities for their construction workers. Portable toilets or similar temporary toilet facilities shall be located only on the Owner's lot. Portable toilets are not permitted in the parkway landscape area. Portable toilets must be maintained and serviced according to city requirements.
5. Property is to be maintained in a clean and orderly fashion during construction. All rubbish and unsightly material, objects and debris of any kind shall be removed daily and will not be allowed to accumulate on the streets, sidewalks, parkway landscape or Common areas. The Owner will be responsible for any trash/debride cleanup work performed by the Association. Owners are prohibited from dumping, burying or burning trash / debris anywhere within the Community. Concrete trucks washing out their spill pans before leaving the construction site shall do so only on the Owner's lot per the city standards.
6. Association Common Areas are defined as the streets, sidewalks, common areas and parks, open spaces, etc. maintained by the association around the lot.
7. Dumpsters, storage pods, construction trailers, cement mixers, and other similar equipment shall be stored on the Owner's lot, not on the Association Common Areas.
8. Special permission from the TMC is required to place a dumpster, storage pod or similar containers and/or equipment on the Association's street prior to ordering the dumpster, etc. The dumpster, storage pod and similar containers must be placed atop strong support blocks so that the unit does not leave imprints or damage on the asphalt street. If permission is granted, the unit must be placed in front of the Owner's home. The dumpster must be removed immediately when full. City permits may be required, and the owner shall adhere to all city codes.
9. Contractors should adhere to city and county guidelines to perform work. The following hours must be adhered to:

7:00 AM — 6:00 PM

Monday through Friday

8:00 AM — 6:00 PM

Saturdays

**No construction on Sundays and recognized holidays**

In an event that the governmental requirements are more restrictive than those listed in the TMC Rules, Regulations, and Policies and the Architectural Guidelines, the stricter governmental requirements shall prevail.

### **Maximum Heights**

The maximum building heights of all Improvements shall be consistent with the County of Orange and/or City of San Clemente zoning codes.

### **Setbacks**

Setbacks are measured from the face of the wall / fence to the side of the improvement closest to the wall/fence. The improvement shall be setback so that it clears the minimum required distance. For Patio Covers, Pavilions, Trellises, Gazebos, and Accessory Buildings, etc. the measurements are taken from the overhang to the face of the wall / fence. If the governing agency's setback requirements differ from those listed in the Architectural Guidelines, then the stricter setback requirement shall prevail.

### **Exterior Stairs**

The location, material, and color of the new exterior stairs shall be compatible with the existing house architecture. Stair supports must be designed as integral parts of the house. Pipe columns are not permitted. Prefabricated metal stairs are not permitted. Spiral stairs may be permitted if they are compatible with the house architecture.

### **Roofing, Skylights**

The slope, material, color, and texture of any new roof shall be identical to the existing roof. Flat roofs are not permitted. The color of the new roof flashing, diverters, vent stacks, and similar features must match the existing roof color. The color of the new gutters must match the existing fascia or adjacent painted surface. Roofs of asphalt shingles, gravel, plastic, fiberglass or corrugated metal are not permitted.

Skylights are to be designed as an integral part of the roof. Their form, location, and color should be compatible with and relate to the building.

#### **Items Required for Submission:**

- Sample or color photos and literature of roofing materials.
- If adding skylights, provide literature describing and illustrating the skylights. Provide an accurately scaled roof plan showing the exact size and location of the skylights.

### **Exterior Building Walls**

Exterior veneer materials used on the building walls shall be consistent on all elevations of a residence to achieve a uniform appearance. Stone and brick veneer shall terminate at an inside corner to conceal the thin profile of the material and be used to distinguish building masses. Predominant veneer materials and accents shall be sympathetic to the original architecture. Painting of any existing brick, tile or stone veneer is not permitted. The introduction of new materials or architectural details inconsistent with those used throughout the community is not permitted.

### **Solar Energy Systems**

Solar energy systems are subject to review by the Association. Detailed plans that outline the following:

- Solar energy systems, both thermal and photovoltaic, can represent a large visual impact on a structure due to their size. Therefore, it is important to properly integrate the system into the design of the house to give maximum advantage to the user with minimal design impact on the community.
- Solar energy systems shall be in the least visually obtrusive location (including, but not limited to, consideration of roof orientation and type, topography, visibility from the Common Area and surrounding properties) where the system can operate effectively.
- The solar panel array and/or power wall must be installed in a location that meets all local building codes and regulations, and in a way that does not cause any damage to the structure of the home or the surrounding property.
- All wiring is to be housed in a conduit painted to match the adjacent surface.
- The frame of the solar panel array is to be a dark color, not clear anodized aluminum.
- Piping going directly to the solar conduit is to be painted to match the adjacent surfaces.
- Power walls and other equipment, other than inverters and emergency shut off, must be installed inside or in a location that is not visible from the street, any common areas, or adjacent property.
- Solar panel array must be installed flush / parallel to the roof line.
- Trees may not be removed to facilitate the installation and operation of the panels without prior written approval by the Design Review Committee.
- The solar panel array should be designed with safety in mind. This includes ensuring that the panels are securely anchored to prevent them from falling or shifting. It is advisable to contract a licensed electrician to install and maintain the Solar Energy System.
- Calculations shall be provided showing the number and area of collectors required.
- The homeowner is responsible for maintaining the solar panel array and/or power wall in good working condition and for any necessary repairs.

### **Items Required for Submission:**

- Signed agreement from homeowner on title and contractor providing solar installation.
- Complete roof plan indicating the location, the type and number of solar panels in each location. Also, indicate the north, south, west and east facings on roof plan.
- An aerial photo of the lot and home indicating location of panels on roof.
- A color brochure showing the proposed solar panels associated equipment.

The DRC reserves the right to require an applicant to paint, screen, relocate or reconfigure a proposed solar energy system unless the applicant can provide the DRC with written notice from the applicant's service provider that function will be unduly impacted by the DRC requirement.

**Reflective Finishes**

No highly reflective finishes (other than glass, which may not be mirrored) shall be used on exterior surfaces (other than surfaces of hardware fixtures) including without limitation the exterior surfaces of any of the following: roofs, all projections above roofs, retaining walls, doors, trim, fences, pipes, equipment and paving.

**Basketball Backboards**

Permanent basketball backboards (those backboards attached to a house or otherwise permanently placed in the ground) are discouraged and will be only allowed as determined on an individual basis upon review by the DRC. Should any such application be approved, certain conditions shall apply to that approval as stated in the letter of approval. Failure to comply with any stated conditions of approval within the decision letter shall result in the revocation of the approval. Permanent basketball backboards are NOT authorized for installation in front yards. (Exhibit E-5) All other backboards not meeting the definition of a "permanent basketball backboard" as defined herein shall be considered a "portable basketball backboard." Portable basketball backboards are allowed on a homeowner's property so long as they are located so that their use does not cause damage to a neighboring property or interfere with the ability to park vehicles on the driveway. Portable basketball backboards are not allowed on community streets (including cul-de-sacs), sidewalks, parkways, driveway aprons, or any other TMC common area. No other sports apparatus shall be constructed or maintained on a homeowner's lot, to disturb any other lot or street within the community. (See the TMC Rules, Regulations & Policies)

**Skate Ramps**

All recreational ramps are to be kept in the rear yard and shall be screened from sight from neighboring homes. A minimum setback of 5 feet from the property line or a distance equal to the structure's height will be enforced. No lights are permitted on the ramps.

**Sports Netting**

All sports netting shall not be used around the perimeter property line walls unless reviewed for approval on an individual basis by the DRC.

**Sporting Equipment****Items Required for Submission:**

- Description of materials to be used and where they are applied.
- Accurately scaled and dimensioned site plans showing the proposed location. When selecting a location be sensitive to the impact of the noise and view of the sports equipment from the adjacent neighbors.
- Accurately scaled and dimensioned elevations of proposed and existing structures to support the equipment /court, if applicable. Existing structures may be illustrated with photos.
- Color, composition and height of new fences or walls, if applicable.

- An accurately scaled site plan illustrating the location of existing and proposed improvements as well as the following:
  1. Include a profile of the applicant's home as well as adjacent homes to clarify their proximity to proposed improvements.
  2. Equipment type & location.
  3. Include property line locations and top of slope location(s) as applicable.
  4. Location and height of new walls or fence required to support the equipment installation, if applicable.
  5. Lighting type and location, if applicable.

### **SHADE STRUCTURES**

#### **Awnings**

Awnings shall complement the color and design of the existing house. They must be simple in design and a solid color. The size, location, and form must be in scale with the window. Temporary sunshades attached to the outer wall of the house, patio cover, or gazebo - such as rolls of bamboo, fiberglass or reed are not permitted.

#### **Patio Covers, Trellises, Arbors, Gazebos, Decks, Playhouses, Play Structures & Other Structures**

The appearance of fixed-mounted patio covers and other exterior structures, such as gazebos, must be consistent with the Architecture of the house. Where stone and wood materials are used, the color must match the house trim or the wall color or must be compatible with the house. The pitch and material of sloping solid roofs must match the roof pitch and material on the house. Thatched roof (Palapa type) shade structures are not permitted regardless of use of natural or artificial materials.

All horizontal roofs must be at least 50% open. Decorative features such as lattice may be incorporated into the design of the patio cover, but the features must be consistent with the character of the community of Talega. Columns may be stucco, precast concrete or wood. Side elevations of structures shall not be enclosed in any manner, except in the case where a wall of a residence forms a natural enclosure for some or all portions of a side elevation. Any exceptions will be reviewed on a discretionary basis by the DRC. Properties adjacent to fuel modification areas may be subject to Orange County Fire Authority special fire protection ordinance and meet non-combustible structure requirements.

#### **Items Required for Submission:**

- Description of materials to be used and where they are applied.
- Accurately scaled and dimensioned elevations of the proposed and existing structures. Existing structures may be illustrated with photos.
- Example of proposed structure including color. A brochure sample is acceptable.
- An accurately scaled and dimensioned site plan illustrating the location of existing and proposed improvements as well as the following:
  - Include color photographs of applicant's home as well as adjacent homes to clarify their proximity to proposed improvements.
  - Include property line locations and top of slope location(s).
  - Lighting type and location.

- Measurements of structure and setbacks.

### **Requirements by Structure Type:**

#### **1. Gazebos, Pavilions**

Definition: Freestanding structures (sometimes pre-manufactured) with "pitched roofs."

Roofs can be "open" trellis type or have "solid" roofing material.

Materials: Wood construction or a material which simulates the appearance of wood (i.e., wood grained aluminum and wood grained vinyl), color and detailing shall match existing house color(s) and style. Roof material (if solid) shall match existing house material and color.

Columns may be wood, or stucco / precast concrete with stone or brick veneer.

Maximum Height: **Thirteen (13') feet**

Rear Yard Setback Requirement: **Minimum five (5') feet** from property line, perimeter fence/wall and/or top of slope, whichever is more restrictive. The setback measurements are taken from the overhang to the face of the wall/fence.

Side Yard Setback Requirement: **Minimum five (5') feet** from property line, perimeter fence / wall and / or top of slope, whichever is more restrictive. The setback measurements are taken from the overhang to the face of the wall / fence.

#### **2. Patio Cover, Pergolas**

Definition: Shade structure or material which simulates the appearance of wood (e.g., wood grained aluminum and wood grained vinyl) with "open" trellis type (normally flat) roof. Materials: Wood construction, minimum 4x4 post size, minimum 2x3 lattice size or a material which simulates the appearance of wood (e.g., wood grained aluminum and wood grained vinyl). Color and detailing shall match existing house color(s) and style. Columns may be wood, or stucco / precast concrete with stone or brick veneer.

Maximum Height: **Thirteen (13') feet**

Rear Yard Setback Requirement: **Minimum five (5') feet** from property line, perimeter fence/wall and/or top of slope, whichever is more restrictive. The setback measurements are taken from the overhang to the face of the wall / fence.

Side Yard Setback Requirement: **Minimum three (3') feet** from property line, perimeter fence/wall and / or top of slope, whichever is more restrictive. The setback measurements are taken from the overhang to the face of the wall / fence.

#### **3. Arbors**

Definition: Shade or accent structures with "open" trellis type (normally flat) roof.

Materials: Wood construction, minimum 4x4 post size, minimum 2x3 lattice size or decorative iron with a design that is consistent with the architecture of the home.

Maximum Height: **Thirteen (13') feet**

Rear Yard Setback Requirement: **Minimum five (5') feet** from property line, perimeter fence / wall and / or top of slope, whichever is more restrictive. The setback measurements are taken from the overhang to the face of the wall/fence.

Side Yard Setback Requirement: **Minimum three (3') feet** from property line, perimeter fence / wall and / or top of slope, whichever is more restrictive. The setback measurements are taken from the overhang to the face of the wall/fence.

#### 4. Trellis

Definition: While similar in structure, an arbor is major, while a trellis is smaller and more delicate.

Materials - Trellis: Wood construction or decorative iron with a design that is consistent with the architecture of the home.

Maximum Height - Trellis: **Eight (8') feet** or when adjacent to a neighboring or common area property line wall, no taller than the wall.

Yard Setback Requirement: Trellis shall not be attached to the property line wall / fence.

#### 5. Deck, Balcony

Definition: Wood structure elevated above the ground. Normally intended for "live loads" (e.g., walking or sitting on).

Materials: Wood construction. Color and detailing shall match existing house color(s) and style. Columns may be wood, or stucco / precast concrete with stone or brick veneer.

Maximum Height: **Thirteen (13') feet**

Deck, Balcony Railing: **Minimum 42" inches, maximum 48" inches.**

Rear Yard Setback Requirement: **Minimum ten (10') feet** from property line, perimeter / wall and/or top of slope, whichever is more restrictive, if elevated above the ground more than two (2') feet.

Side Yard Setback Requirement: **Minimum five (5') feet**, perimeter fence / wall.

#### 6. Playhouses, Play Structures, Trampolines, etc.

Definition: Any large structure or apparatus used for play or recreation that's height is above the property fence line.

Materials: Wood, plastic or metal construction. Wood must be stained, painted and/or sealed. Colors and aesthetics should be complementary to, or match, the colors of the existing home.

Maximum Height: **Thirteen (13') feet**

Rear Yard Setback Requirement: **Minimum five (5') feet** from property line, perimeter fence/wall and / or top of slope, whichever is more restrictive. The setback measurements are taken from the overhang to the face of the wall/fence.

Side Yard Setback Requirement: **Minimum five (5') feet** from property line, perimeter fence/wall and / or top of slope, whichever is more restrictive. The setback measurements are taken from the overhang to the face of the wall / fence.

LIMIT ONE (1) PER LOT. Playhouses, play structures, trampolines, etc. must be shielded from public view, including neighboring residences with appropriate plant screening.

The design of all large play structures must include a construction plan with dimensions, elevation view (decks attached to house must provide rear and side elevation including existing house elevations and photos) and construction details / catalog cut sheets.

The above standards shall be used with the individual tract supplemental declarations and the applicant's submittal shall adhere to the stricter criteria. The DRC can approve standards less than above individually.

### **Sundecks**

1. No sundecks are permitted on or over any portion of a two-story roof. Heights will be limited to the existing living levels. Sundecks on or over any portion of a one-story roof will be considered on an individual basis by the DRC based on the suitability of the design and whether the purpose of the Architectural guidelines are achieved.
2. Sundecks may be directly accessible from the living area level or from the ground level; however, stairs to upper-level deck area may not extend into any side yard setbacks.

### **Additions, Casitas, Remodels, Exterior Modifications**

The architectural design of the structure must be compatible with the existing structure with respect to massing and articulation. Window openings shall be consistent with existing windows in proportion and arrangement on any given exterior wall elevation. Window detail, door designs, roof tiles, roof slopes and pitches, and roof overhangs, gutters, downspouts, light fixtures, etc. and other architectural elements

shall be consistent with the design of the home. All finish materials, colors and textures for alterations or additions shall match existing finishes on the home.

Maximum Heights:

- a. Second Story Addition - **The height shall not exceed the existing second story roof line of the home (chimney excluded).**
- b. Casitas and Similar Accessory Dwellings - **The maximum height shall not exceed fifteen (15') feet.**

Rear Yard Setback Requirement: **Minimum ten (10') feet** from property line, perimeter fence / wall and / or top of slope, whichever is more restrictive. The setback measurements are taken from the overhang to the face of the wall / fence. Exceptions to the rear setback for structures with hip roofs will be considered by the DRC on an individual basis.

Side Yard Setback Requirement: **Minimum five (5') feet** from property line, perimeter fence/wall and/or top of slope, whichever is more restrictive. The setback measurements are taken from the overhang / eave to the face of the wall/fence.

Items Required for Submission:

- Accurately scaled and dimensioned floor plans, roof plans and exterior elevations of the proposed and existing structures.
- An accurately scaled and dimensioned site plan illustrating the location of existing and proposed improvements as well as the following:
  1. Include photographs of applicant's home as well as adjacent homes to clarify their proximity to proposed improvements.
  2. Include property line locations and top of slope location(s).
  3. Retaining walls, fences and gates.
  4. Existing and proposed drainage system as well as current slope / drainage pattern and grades.
  5. Description of materials to be used and where it is to be applied. Physical samples may be required.
  6. Lighting type and location.

**Garage Conversions (limited to the original builder options floor plans only)**

Garage conversions (garage floor area converted to livable floor area) will be considered on an individual basis. The DRC will only consider the builder options and parking in the immediate area. Garages (except

rear tandem spaces) converted to livable floor area may, on an individual basis, be required to have the garage doors replaced with conventional wall and door and windows assemblies to match the existing residential architecture. Supporting landscape may be required under the DRC's advisement. In no case will a garage conversion be approved which reduces the garage space count below two car spaces.

### **Garage Doors**

Garage doors with or without a window panel when replaced shall be consistent with the architecture of the home and within the design context of the community. Garage doors made of wood may be stained to match the house's front door if permitted by the DRC.

### **Temporary Buildings & Sheds**

Playhouses, sheds, shacks or other temporary buildings or Improvements may not be placed upon any portion of the Properties either temporarily or permanently, without the prior written consent of the DRC. Any such temporary building shall be shielded from the view of adjacent neighbors and from the street. Sheds utilized for storage place must be painted or stained to match the house paint scheme and their height may be no higher than **six feet ten inches (6'10")**.

### **Barbeque, Bar Structures**

Barbeque/bar structures must be setback a **minimum of three (3) feet** from any property line. Setbacks are measured from the face of the wall / fence to the side of the improvement closest to the wall/fence.

### **Fireplaces and Fire Pits**

Outdoor fireplaces, fire pits, or other similar items must be setback from any property line, perimeter fence/wall and / or top of slope a **minimum of five (5) feet** and must be natural or propane gas burning only. If the proposed structure is higher than the adjacent wall or fence, a setback equal to or greater than the height of the structure is required, whichever is more restrictive. Maximum height shall not exceed **thirteen (13) feet** (including spark arrestor) measured from original pad elevation. **For example, an eleven (11) feet high fireplace** must be set back **eleven (11) feet minimum** from both rear and side property lines. Structure must be screened with evergreen plant material. (See Exhibit E-6)

### **Air Conditioners**

Air conditioners may be installed subject to prior written approval from the TMC. Any such equipment shall be screened from view from adjoining residences and streets.

## **GENERAL LANDSCAPE STANDARDS**

### **Landscape / Hardscape**

Landscaping can be effectively used to accent entryways, define space, and create "soft" privacy screens. Since landscaping is a design element, the same consideration should be given to the relationship of the applicant's residence to adjacent residences.

1. All landscaping, plantings, and installation of permanent irrigation systems by the Owner shall remain aesthetically consistent with the community's design and plan. Please refer to the recommended plant palette for Talega, which is attached as Exhibits DI-D7. Other tree and plant species and cultivars may be approved on an individual basis.
2. Trees, hedges, and shrubs which restrict sight lines for vehicular traffic from neighboring units shall be cut back or removed.
3. Rock, gravel, bark, mulch, decomposed granite, and large rock or boulders may be incorporated into front yard landscaping; however, they may not be used as the main component of the landscaping. No more than 30% of the landscape as measured by the square footage of the softscape may be exposed rock, gravel, bark, mulch, decomposed granite or large rock. Colors must be of natural earth tones and must harmonize with the existing landscape and architecture. A two (2) inch thick layer of wood mulch is recommended to cover bare soil around plants to prevent excessive weed growth, provide plant nutrients, and prevent water evaporation.
4. Within 12 months of installation, areas where ground cover or shrubs have been planted should grow and spread to cover 75% of the intended area. This Standard does not include areas covered by turf.

#### **Creating Visual Barriers or Privacy Screens**

Any plant material, including trees and shrubs, planted to create a visual barrier / privacy screen will be reviewed by the DRC on an individual basis. The use of more than three (3) Italian Cypress (*Cupressus Sempervirens*) or other similar trees in a row to create barriers / screens along property lines is not permitted. Exceptions to this rule will be reviewed on a discretionary basis for approval by the DRC.

Interchanging plants with drought tolerant plants will be reviewed at the discretion of the DRC's guidance in accordance with sustainable parkway plans.

#### **RESTRICTIONS**

Use of certain trees may be restricted in their use due to the proposed location on the property. Although trees may be listed as recommended in these Guidelines, each Applicant has the responsibility of selecting trees appropriately scaled for the intended location. The homeowner is responsible for ensuring that no trees are planted too close to any structure which may cause potential damage to that structure or infrastructure such as sidewalks and drain lines. All proposed trees along property lines should be setback a **minimum of five (5') feet**, measured from the trunk to the inside of the property line wall, or far enough to prevent tree canopy, at maturity, from extending into neighboring yards or over community sidewalks. All trees shall be planted with root barriers, **24" deep**.

Calif. Sycamore, Ficus, Coral Tree, etc. — Known to have invasive root systems are not to be planted near property line or community walls where damage could potentially occur. Ample space shall be provided for trees with large roots and canopy systems.

Giant Bird of Paradise Trees, etc. — Not to be planted on side yards immediately adjacent to property line walls/fences.

**Items Required for Submission:**

An accurately scaled and dimensioned site plan illustrating the location of existing and proposed improvements as well as the following:

1. Include property line locations and top of slope location(s).
2. Include a profile (illustrated on site plan) of applicant's home as well as property lines to clarify their proximity to proposed improvements.
3. All proposed and existing sidewalks and planters.
4. Description of materials to be used and where they are applied. Provide a Material Board or color photographs/color brochures for all proposed Hardscape Materials (colored concrete, stone veneer, brick, concrete caps, etc.).
5. Description and layout of proposed and existing plants and trees. The description should identify the full size of plant and the tree size at maturity. If proposing artificial turf provide a sample & literature of the product.
6. Existing and proposed sprinkler / irrigation system.
7. Existing and proposed drainage system as well as current slope / drainage pattern and grades.
8. Existing and proposed shade structure(s).
9. BBQ and/or fire pit location and type.
10. Lighting type and location.
11. Detailed drawing/elevation with dimensions, setbacks, measurements, colors and materials for all raised elements.

**Thematic Items, Fountains and Statuary**

Landscaping themes involving statues or fountains are limited to back or side yards and shall be setback a **minimum of three (3') feet** from property lines. Fountains adjacent to wrought iron or glass fencing may require buffering from the view of neighboring residences and common areas with appropriate planting. The overall height of thematic items, fountains and statuary shall not exceed the height of the adjacent wall / fence. Any exception to the **three (3') feet minimum** setback for statues or fountains will be reviewed by the DRC on an individual basis. Statues or fountains adjacent to property lines located on side yards may not jeopardize pool safe fence / wall requirements to adjacent neighboring property.

NOTE: Refer to the City of San Clemente Building Code requirements.

The color of statuary and sculptural elements should complement the primary residential structure. Bright colors and reflective surfaces are not permitted.

Thematic landscape features with eccentric colors, forms, or materials that establish an independent theme that detracts from the overall streetscape, such as excessive glass block, mirror balls, pink flamingos, rock gardens, gravel yards, railroad ties, and split rail fencing are not permitted in private yards visible to the streets.

Fountains are not approvable in the front yard unless they adhere to the following: (a) height of the fountain (measured from original pad elevation to top of fountain) shall not exceed **three feet six inches (3'6") maximum**, (b) shall be simple in design and not be the focal point of the front yard landscaping, (c) shall be placed within a planter area with appropriate evergreen plant material for immediate screening, and (d) shall be setback a **minimum of three (3') feet** from any property line. Elevations of the fountain and the proposed screening material must be submitted for review. Improvement(s) must meet all local and state codes.

### **Pools, Spas and Rockwork**

Pools, Spas and similar water features such as reflecting pools and koi ponds are permitted in private yards not visible from the street. Pools, spas, including above ground spas and similar water features require a **five (5') feet minimum** setback from any property line and must be adequately screened from view. If the governing agency requirements are more restrictive than those listed in the Architectural Guidelines, then the stricter governing agency requirements shall prevail. All equipment shall be completely screened from the view from the street and all equipment installed near wrought iron fencing shall be buffered from the view of neighboring residences with appropriate planting.

- Please note the City of San Clemente requires a **five (5') feet minimum** clearance for pool equipment from any property line. A setback of **less than five (5') feet** will be permitted by the city, providing that it is soundproofed to the satisfaction of the city building official and the degree of soundproofing is demonstrated in an acoustical report approved by the city building official. In no case shall the clearance be **less than two (2') feet**.

Rockwork, slides or similar features may not exceed the height of adjacent property line walls or fences. They must be setback from any property line or top of slope a, whichever is more restrictive. In an event that the governmental requirements are more restrictive **minimum of three (3') feet or equal their height** than those listed in the Architectural Guidelines, then the stricter governmental requirements shall prevail. Lots with down slope at the rear of the property may require a **greater than five (5') feet** setback from the rear property line. Due to expansive soils typical in much of San Clemente, the DRC may require the homeowner to submit a soils report by a licensed Geotechnical or Civil Engineer that addresses the location of the pool / spa, soil conditions and slope stability. (CC&R 13.3).

- Description of materials to be used and where they are applied.
- Accurately scaled and dimensioned pool / spa plans.
- Accurately scaled and dimensioned elevations of proposed and existing structures to support the new pool or spa. Existing structures may be illustrated with photos.
- Color, composition and height of new fences or walls.
- Pump and filter data and noise control measures.
- Calculations and geological report, for record keeping purposes only. An accurately scaled and dimensioned site plan illustrating the location of existing and proposed improvements as well as the following:

1. Include photographs of the applicant's home and adjacent homes to clarify their proximity to proposed improvements.
2. Pool and Spa location.
3. Include property line locations and top of slope location(s) as applicable.
4. The location and height of new walls or fences is required to support the pool installation.
5. Pump and filter equipment location and noise rating.
6. Lighting type and location.
7. Soil Report Acknowledgement signed by homeowner.

**IMPORTANT NOTE:** Prior to submission of a pool/spa plan to the DRC, we highly recommend the homeowner have their contractor check with the City of San Clemente regarding the soil conditions and slope stability specific to the location of the pool / spa on the lot, as these conditions may require a greater than 5'0" setback from the property line.

### **Walls, Fences and Gates**

1. Fences of chain link, poultry wire, woven wire, aluminum, sheet metal, plastic, fiberglass, reeds, straw, bamboo, rope, vinyl and other similar temporary or commercial materials are not permitted.
2. Side gates shall be a **maximum of four (4') feet** wide and may be wood or tubular steel and must match the aesthetics of the house and surrounding community. They shall be painted or stained to match the adjacent property line wall or the color scheme of the residence. Details of all gates (material, design, color, etc.) and dimensions must be provided for consideration by the DRC. A cut sheet or photo may be submitted.
3. Side yard return walls shall be composed of the following materials:
  - a. Solid CMU slump block wall textured and painted to match the existing property line walls.
  - b. Return walls with stucco finish shall be painted to match the existing property line walls or painted to match the stucco color of the home. Stone veneer to match the stone veneer on the home or low walls and pilasters in the front yard will be considered on an individual basis.
  - c. **Four (4') feet** wide wood or wrought iron gate with a CMU slump block wall to match the existing walls.
  - d. **Four (4') feet** wide wood gate with a small return fence on one side or both sides of the gate will be considered on an individual basis.
  - e. **Four (4') feet** wide wrought iron gate with a small return fence on one side or both sides of the gate will be considered on an individual basis. A privacy screen (mesh) will be required on both the gate and return fencing.
  - f. Double gates of high-quality design and material will be considered on an individual basis. Gates cannot be installed in association maintained common wall. **IMPORTANT NOTE:** The landscaping design in the area adjacent to the double gate will be a key consideration by the DRC. Double gates are NOT intended for use to store boats or other recreational vehicles on the lot.
4. Refer to Exhibit G1-G4 for samples and additional information on submitting walls, fences and the Talega Pre-Approved gates.

5. Tubular steel fencing may be used in certain situations such as slope conditions and will be considered on an individual basis. A privacy screen (mesh) will be required on any tubular steel side gates / fences behind which trash cans or other utilities would otherwise be visible from the street.
6. No double fences/walls shall be allowed along adjoining property lines.
7. Fencing and walls shall not exceed **six (6') feet** in height and the maximum height for adjoining pilasters, including cap, is **six feet ten inches (6'10")**.
8. Vehicular gate(s) which would permit vehicular access to side/rear yards shall not be permitted.
9. Driveway vehicular access control gates shall not exceed a vertical height of **seven (7') feet** as measured from finish driveway surface elevation and shall be an average of **six (6') feet tall**. Gates shall be set back from the back of front property line/back of sidewalk a **minimum of fifteen (15') feet**.
10. All return walls and gates shall be setback a **minimum of four (4') feet** from adjacent face of house. Exceptions may be permitted due to residence and/or lot configuration, relation to adjacent residence, etc., and will be considered on an individual basis.
11. The replacement of builder-installed rear / side yard walls / fences will be considered on an individual basis. Replacement material and design shall be consistent with the fences and walls in the surrounding tract and shall match adjacent walls and fences in height.
12. Front yard walls shall not be used to enclose large portions of a front yard, but partial enclosure may be considered on an individual basis. The front yard wall shall not exceed six (6') feet and must be setback at least fifteen (15') feet from the property line/back of sidewalk.
13. Walls and pilasters at the front yard are not permitted within the public utility easement and must be setback a **minimum of three (3') feet** from front property line / back of sidewalk. Wall height shall not exceed **three feet six inches (3'6")** maximum and the maximum height for adjoining pilasters, including cap, is **four (4') feet**.
14. A **two (2') feet minimum** wide planter area shall be installed wherever the lot is bordered by open wrought iron fencing. Low walls shall not terminate into open wrought iron fencing.
15. Where soil is retained at existing property walls (**1' max. retainage**), a flash wall and adequate waterproofing is required to protect the existing walls.
16. Height of planter walls adjacent to common property lines may not jeopardize pool safe fence/wall requirements adjacent to neighboring property and shall not exceed **24" height**. NOTE: Refer to the City of San Clemente Building Code requirements.
17. In cases where the property line wall is proposed to be extended, written permission / authorization from the adjacent impacted neighbor for construction on the common property line is to be submitted.
18. In cases where the common property line wall proposed to be extended is shared with the Association, written permission / authorization from Talega Maintenance Corporation is required. Please contact Management for assistance.
19. Modifications of the Neighborhood Builder property line walls and fence as-built surface finish are not approved for any portion of the wall or fence that is visible from the street including wall steps, street front faces, or for walls with downslope easement exposure. Interior surface finish modifications must be DRC approved and are not allowed for property line walls that are not brick capped.

**Alternative Fences and Gates**

Vinyl and other alternative building materials will be considered on an individual basis for replacement fences and gates. The fence and gate material shall be wood grained with a matte / satin finish (no high gloss finishes). Vinyl and other alternative building materials for sub-association gates shall be considered on an individual by the sub-association's Architectural Committee and the DRC.

**Items Required for Submission:**

1. Property Improvement Form
2. Neighbor Awareness Form
3. Description of materials to be used
4. Overview Map of Property designating property lines
5. Photos of existing fence/gate
6. Dimensions of proposed fence/gate

**Drainage**

Area drains must be installed in private yards for adequate drainage to permit the plants to survive and to minimize the ponding of water. There shall be no interference with the established drainage patterns over any lot, or Common Area, unless an adequate alternative provision is made for proper drainage. The landscape irrigation system should be designed to prevent excessive saturation of soils. Planters created by walkways next to a residence should be a **minimum of six (6") inches** below weep screed and drain away from house surface and should contain drain inlets to drain excess water.

**Parkway Street Trees**

The parkways (the area between the street and the sidewalk) in the neighborhoods have been lined with trees and grass and were designed to be and are an integral part of the plan of Talega. In single-family home neighborhoods, the homeowner shall maintain the parkway between the curb and sidewalk per the legal documents. In the single-family home neighborhoods without parkways, the required tree(s) were planted in the front yard by the builder. This tree must remain unless otherwise approved by the TMC Board of Directors for removal. If a parkway street tree dies for any reason and / or the tree becomes too large for the parkway that may cause damage or is causing damage to the sidewalk, utilities, mailboxes or other items, the homeowner shall be responsible for the cost of removal and replacement of the parkway street tree and installation of a new tree.

Trees installed by the builder shall not be removed and shall be maintained, repaired, and irrigated by the homeowner. Maintenance of parkway street trees, and in fact all trees, bushes, shrubs, and other planted material on a lot shall include, but not be limited to, trimming said trees, bushes, shrubs, and other planted material so that they provide clearance for pedestrians, vehicles, street sweeper, fire lane sign, street sign and stop sign visibility or lines of site. Existing parkway street trees need to be shown accurately on all landscape plans. If a homeowner wishes to relocate an existing parkway street tree(s) it must be noted clearly on the plan. Any such request may be approved as determined on an individual basis by the Enforcement Committee.

If a homeowner wishes to remove the existing parkway street tree(s), this request must have approval from the Enforcement Committee.

Parkway street trees installed by the Builder shall be inspected by the Enforcement Committee or Talega Maintenance Corporation annually or at any other interval as reasonably deemed necessary by the Enforcement Committee or TMC.

Should a homeowner fail to replace the parkway street tree(s) the Enforcement Committee shall proceed with the violation process and may fine the homeowner consistent with TMC fine schedule.

### **Artificial Turf**

Artificial turf may be used in front, rear and side yards according to the following conditions listed below. Artificial turf must be approved prior to installation by TMC.

#### Location

To be used only as an enhancement, accessory to or to complement the main landscaping features in front yard landscaping, and not as a major focal landscaping feature.

1. Turf to be installed within a border such as a concrete strip, sidewalk, brick planter, etc.
2. In no case should the artificial turf be adjacent to regular turf on the same lot or adjoining property.
3. Artificial turf is not permitted on slopes steeper than a footage ratio of 4:1 maximum.
4. Turf must be natural in appearance.
5. Turf uniformity must be maintained for all areas that are visibly linked.
6. Must provide an accurate drawing of drainage for the turf area that does not interfere with Association irrigation.
7. Turf cannot be placed directly on top of existing grass, dirt or hardscape.
8. If artificial turf is being proposed in the parkway the irrigation must be adjusted and maintained for the parkway tree.
9. If artificial turf is being proposed in the parkway a tree well must be established to properly maintain the health of the parkway tree. The tree well dimensions will be the full width of the parkway planter and the turf should be 24" away from the trunk of the tree.
10. Homeowners are responsible for always maintaining the artificial turf in a clean and attractive condition.

#### Material

1. The turf must be of a recognized high-quality product and must be of a natural color, texture, and density. Sample cut sheets or photos of the proposed turf shall be submitted for review.
2. Must provide an adequate base/drainage under turf.
3. Turf is required to have a pile height at a minimum of 1 1/2 inches.
4. Turf weight must be a minimum of seventy (70) ounces per square yard.
5. Turf must have a minimum 1-year installation and workmanship warranty. The turf must have UV protection.
6. Anti-microbial turf recommended to avoid foul odors, discoloration and corrosion.
7. Consistent with all property improvements throughout Talega, the turf must be maintained in an attractive manner as determined by the Board of Directors.

**Paved Areas**

Driveway expansions are not permitted, except for a maximum two (2') feet wide band on each side. The bands are to match the existing concrete or materials used in the landscape / hardscape. All exterior paved areas exposed to streets and rights-of-way shall be one of the following:

- Masonry unit (stone, brick, tile, concrete pavers, flagstone)
- Textured, colored or plain concrete
- Exposed aggregate concrete
- Combinations of the above

In no case shall precision / polished or high gloss stone / tile materials be approved in front yards or yard areas visible from the street.

If an adjacent walkway leading to the front door is proposed or existing, the planting area between the expanded driveway and walkway must be a minimum of twenty-four (24) inches wide for the length of the driveway.

Continuous Buffer Zone – A minimum twenty-four (24) inch continuous buffer zone of plant material must be maintained between the driveway / hardscape and the property line or median.

**Driveways, Walkways, and Aprons****Driveway Excluding Apron**

The driveway material should be harmonious with the overall aesthetic of the property. Suitable materials include (stamped) concrete, pavers (brick, stone, flagstone), or cobblestone.

**Walkway Excluding Sidewalk**

The walkway material should provide a safe and inviting path for pedestrians while complementing the design of the property. Suitable materials include (stamped) concrete, pavers (brick, stone, flagstone), or cobblestone. The material should be slip-resistant and capable of withstanding foot traffic and weather conditions.

**Apron**

The apron, which connects the driveway to the street, serves as a transition zone and must not be modified. Repairs may only be done using flat concrete in the same color of the original concrete. Driveways and walkways should be designed with appropriate slopes and gradients to facilitate water drainage and prevent pooling or runoff issues. Lighting may be installed along the driveway and walkway to enhance visibility and safety, particularly during evening hours.

**Lava Rock and Decorative Rock**

Rock and / or gravel must not be the dominant or the primary feature in the front yard. Decorative rock and boulders must be secondary to the landscape. A minimum 3'0" wide planting buffer from the sidewalk / front property line to the rock / gravel, boulders or similar materials is required.

The plan must show the total percentage of the overall front yard to be covered by rock and/or gravel. Colors of rock / gravel used must be harmonious with the house and natural landscape of the community. Bark or mulch must not be the dominant or the primary feature in the front yard and will be considered the same as rock and gravel.

**MISCELLANEOUS****Exterior Painting:**

Any change in the paint color of the exterior of a building or a single-family Residence or change in the location of the existing paint color, regardless of whether submitted by an Owner or a Sub-Association, must receive the written approval by the Design Review Committee. Per Article III, Section 3.4.1 of the CC&Rs, "any improvement may be repainted without Design Review Committee approval so long as the improvement is repainted the identical color which it was last painted." Repainting the identical color means the identical paint color in the identical location on the building / single family Residence.

Please note that if a variance was offered to a neighboring homeowner for paint or any other improvement(s), that does not guarantee any homeowner will be offered the same variance. All variance requests are reviewed on a discretionary basis. Pre-approved paint schemes must still be submitted for and approved prior to commencing work. Under no circumstances are rock veneers to be painted or limewashed a different color.

**Items Required for Submission:**

1. Property Improvement Form to be completed.
2. Neighbor Awareness Form signed and completed by neighboring properties. If there is a hill, slope, or Common Area next to your home, please write that in the space provided on the form.
3. Exterior Paint Selection Form: Clearly outline which colors will be used for each listed area of the home. Fill in color name and circle the listed elements on the home that will be painted for each correlating color written in the highlighted portion on the exterior paint submittal form.
4. Color photographs of the front, both sides & rear of the home. Color photograph(s) of neighboring home(s) on each side and directly in front of the home. Clearly identify property addresses for neighbors in the application.

Paint applications may be submitted by email to [TALEGA@ciramail.com](mailto:TALEGA@ciramail.com) with the property address in the subject line.

### **Exterior Lighting**

Exterior lighting must be of a low illumination level — 150 lumens or less per fixture or low voltage and shielded (cast downward) from direct view from streets and adjacent residences. Higher levels of lighting may be approved if they are neither directed nor placed so that they create an annoyance to the neighbors. Light poles shall not exceed the height of the adjacent wall or fence. Café-style lighting hung in the yards year-round shall be uniform in color tone and have a kelvin level between 2700K and 5000K. Landscape lighting shall be setback from the front property line a distance equal to its height and shall not exceed the height of the adjacent wall / fence. All exterior light fixtures must be ornamental (no flood lights, exposed fluorescent lamps, flashing lights) and submitted for review.

### **Under Eave Lighting Design Standards (adopted 10/14/2025)**

Permanent under-eave lighting will be permitted with prior approval from the Design Review Committee, provided such lighting is concealed appropriately and used no more than 60 calendar days per year for holiday display purposes.

1. Fixture Location – All fixtures must be mounted beneath the eave or soffit and fully concealed from direct view when not in operation. No exposed conduit, wiring, or junction boxes are permitted.
2. Appearance – Fixtures, housings, and trim must be a neutral color that matches or complements the adjacent fascia/eave material.
3. Lighting Characteristics:
  - a. Brightness – Maximum output not to exceed 3,000 lumens total visible from the street at any given time.
  - b. Color Temperature – White light must be in the warm white range of 2700K–3000K for everyday use.
  - c. Colored Lighting – Allowed only for seasonal/holiday display.
  - d. Light Spill – Fixtures must be aimed downward and shielded to prevent glare into neighboring properties, streets, or common areas.
4. Control System – Must include a timer or app-based scheduling feature to comply with operational hours.
5. Standard Operation – White lighting only (2700K–3000K) permitted outside of holiday periods.
6. Holiday Lighting – Multi-color or themed lighting permitted for holiday display up to a maximum of 60 total calendar days per calendar year.
7. Quiet Hours – All under-eave lighting must be turned off between 11:00 PM and 6:00 AM, except or security lighting triggered by motion sensors.

### **Holiday Lighting**

Holiday lighting or decorations are permitted without DRC approval and may be displayed not more than **thirty (30) days** prior to and removed within **fifteen (15) days** after the holiday. Holiday lighting or decorations are not permitted on association Common Areas, including but not limited to streetlights, street signs, walls, monuments or common area property.

**Flagpoles**

The design, material, installation and lighting of flagpoles shall be subject to the review and approval of the DRC and applicable governing law.

**Clotheslines & Drying Racks - Backyards Only**

Clotheslines and drying racks may only be installed in the backyard.

Definition: A "clothesline" to include a cord, rope, or wire from which laundered items may be hung to dry. The use of clotheslines and drying racks are prohibited on a balcony, railing, awning, shade structure or other part of any structure not qualifying as a clothesline and / or drying rack.

The height of a clothesline and / or drying rack may not exceed the height of the perimeter wall / fence and may not be visible from the street. The clothesline shall not be attached to any common area.

**Window/Door Replacement**

Window and door frames shall match the existing design of the community home style. Glass tinting or shading must be compatible with the existing treatment. Mirrored glass, reflective glass film and plastic roll up shades shall not be permitted. Exterior shades of any type shall not be permitted. Window borders shall match existing windows or be painted to compliment the stucco. Stained glass may be approved if it reinforces the architectural style. Grid lite patterns are reviewed on an individual basis and must be in alignment with existing windows, and cohesive to the architecture throughout the community. Replacement windows must be energy efficient and meet or exceed the current energy code standards. Installing retrofit windows is approved by the DRC on a discretionary basis and in accordance with the architecture of the home.

**Items Required for Submission:**

- Sample or color photos of existing windows to be replaced and literature such as a brochure of window / door materials clearly identified.
- Floor Plan showing the location of proposed window replacement.
- Elevations must be clearly marked if new windows are being installed (rather than replacing an existing window).
- All replacement windows must be of a similar style to the original windows. Any changes to the size or shape, color and/or finish of the windows must be approved.
- Indicate on plans whether windows will be retrofitted.
- Specifications of proposed windows / door material, such as dimensions.

**Window Coverings**

Only curtains, drapes, shutters, or blinds may be installed as permanent window covers. No aluminum foil, paint, newspaper or similar coverings deemed to be inappropriate for a window covering shall be applied to the windows or doors of any Residence. Owners may use plain clean white sheets to cover windows after the Close of Escrow pending the installation of drapes, curtains, shutters or other appropriate interior window coverings for 3 months from conveyance of residence from Previous Owner.

**Line of Sight**

Improvements in the limited use areas must not block the line of sight of drivers on the streets adjacent to the limited use areas. Plants and shrubs in the limited use area must not be allowed to grow higher than twelve (12) inches above ground. (CC&Rs, Article VIII, Section 20)

**View Obstructions**

Each owner acknowledges that any construction or installation by declarant, any Guest Builder or the Master Association may impair the view of such owner and hereby consents to such impairment. Each owner acknowledges that there are no guaranteed views within the properties, and no lot or condominium is assured of the existence or unobstructed continuation of any view unless a Supplemental Declaration specifically provides otherwise. (CC&Rs, Article VIII, Section 16)

**Surveillance Cameras**

Video recording surveillance camera installations must be in compliance with privacy laws governing the collection of personal information. Cameras and / or recording equipment may not impede upon the privacy of neighbors by having camera angles of shared driveway areas and/or an adjacent structure's windows, back or side yards. Cameras may not be trained on Common Area, but not limited to parks, pools, trails, playgrounds or sports fields.

- For exterior installations, plans must identify the location of cameras. Wiring must be hidden from view or painted to match the adjacent surface of the Dwelling.
- Cameras shall not be installed on remote controlled rotating mounts. Cameras must be mounted to be stationary.

**PRE-APPROVED ITEMS****Pre-Approved Sustainable Parkway Modification Plan for each Neighborhood in Talega**

The Board of Directors has approved after input from the Landscape Committee, Design Review Committee, SMWD and the City of San Clemente, a pre-approved sustainable parkway modification plan to homeowners in each neighborhood who want to replace the natural grass in the street parkway. Included with the sustainable parkway plan is a modified irrigation plan which requires abandoning overhead spray heads and modifying the system for drip irrigation to groundcover plants and bubblers for the parkways street tree(s). The parkway street trees are to remain per the supplemental CC&R's, Talega Specific Plan and the City of San Clemente.

By changing to a Sustainable Parkway Plan, owners will benefit by saving water, reducing runoff from sprinkler overspray and successfully adhering to water waste prohibitions issued by the state as well as SMWD.

The sustainable parkway modification plan and modified irrigation plan and the Application for Notice of Completion form for each neighborhood must be submitted after parkway installation and can be requested from Management.

No deviations or substitutions to the plant material or hardscape are allowed on the preapproved plans.

**Wrought Iron Fencing Attachment Material to Control Access of Critters**

IMPORTANT NOTE: This material can only be attached to wrought iron property line fences which are maintained by the homeowner.

1. Galvanized steel hardware cloth, color family is silver metallic. The hardware cloth should be installed partially below ground, and it is recommended that you use plastic ties to secure it to the wrought iron fence. Hardware cloth is helpful in preventing gophers, rabbits, and snakes, etc. from gaining access to the lot.
2. Galvanized steel hardware cloth can be found at Lowe's and Home Depot.
3. No chicken wire, bamboo, wood lattice, ply board and other similar fencing are allowed to be attached to the wrought iron property line fences.

**Rain Gutters and Downspouts**

Any such improvements shall be primed and painted to match the color of the adjacent surfaces.

**Screen Doors**

Applied only to the front door or entrances and shall be required to match the color of the adjacent surfaces.

**Personal Agriculture**

Homeowners may use the "backyard," designated for the exclusive use of the homeowner, to cultivate edible fruits or vegetables for personal use or donation. Dead plant material and weeds, (except for straw, mulch, compost, and other organic materials) intended to encourage vegetation and retention of moisture in the soil, are to be regularly cleared from the backyard.

**Satellite Dishes and Antennae**

1. It is recommended that satellite dishes and antennas be placed in a location on the rear one-third of the house (e.g., tucked behind the chimney) where good reception can be received.
2. If the only location in which good reception can be received is toward the front of the house, the face of the satellite dish and antennae mounting unit/brackets and cable wire are to be painted to match the adjacent surface of the dwelling.
3. Regardless of location, the cable wire will not be permitted to hang free from the roof or any other portion of the dwelling. The cable should be placed along the weep screed or tucked in along the eaves to minimize visibility.
  - a. Areas Under an Owner's Exclusive Use and Control:
    - i. Dishes: Satellite dishes and antennas designed to receive video programming services via multi-point distribution services may be installed in an area under an owner's exclusive use or control so long as such antenna and satellite dishes are (i) one meter

or less in diameter, (ii) installed in the least visually obtrusive portion of an owner's property where an acceptable quality signal can be received, so long as such installation is not unreasonably expensive, and (iii) either screened from view or painted to match the surrounding areas so as to blend in with the surrounding area, so long as such screening or painting is not unreasonably expensive.

- ii. **Broadcast Antennas:** Antenna designed to receive television broadcast signals may be installed in an area under an owner's exclusive use or control so long as (i) an acceptable quality signal cannot be received via an indoor antenna (e.g., an antenna mounted in an attic, "rabbit ears," etc.), (ii) the antenna used is the smallest size available at a reasonable cost that receives an acceptable quality signal, and (iii) the antenna is installed in the least visually obtrusive portion of an owner's property where an acceptable quality signal can be received, so long as such installation is not unreasonably expensive.

b. Areas Not Under an Owner's Exclusive Use or Control

- i. A satellite dish or television antenna may only be installed in an area that is not under the owner's exclusive use or control if (a) the satellite dish or antenna has a diameter or diagonal measurement of one meter or less, (b) the satellite dish or antenna is not visible from any street or common area, and (c) the owner has applied for and received DRC approval for installation of the satellite dish or antenna.

**Changing Address Font Style**

Address numbers and font style shall be replaced to match existing or compliment the character of the community. The address numbers must be illuminated to be visible from the street. The DRC will review a font change on a discretionary basis.

**POLICY FOR THE SUBMITTAL OF A HOME IMPROVEMENT APPLICATION  
PRIOR TO THE CLOSE OF ESCROW**

1. The applicant is responsible for submitting a complete Home Improvement Application ("application") to the Design Review Committee (DRC) in a manner consistent with the Architectural Guidelines of the Talega Maintenance Corporation (TMC).
2. The "application" and the architectural plans must be signed by a representative of the seller, as the landowner of that property.
3. The applicant must ensure that the Neighbor Statement has been signed by all relevant parties (e.g., impacted neighbor, adjacent neighbor, facing neighbor). The Seller is required to sign the Neighbor Statement if any relevant party has not closed escrow.
4. The applicant must submit his or her signed Disclosure Statement.
5. The application fee is non-refundable even if the transaction does not close escrow.

6. The "application" will be reviewed at the next meeting in the same order in which "applications" are submitted. The DRC currently meets once per month.
7. Applicant understands that the "application" must be consistent with the TMC Architectural Guidelines as determined by the DRC. The TMC makes no guarantee that applicant's "application" will be approved prior to the close of escrow.

### NEIGHBOR DISPUTE POLICY

This policy is to address situations where homeowners request the Talega Maintenance Corporation (TMC) to act on neighbor-to-neighbor disputes.

Before the association takes enforcement action on a neighbor-to-neighbor dispute matter, the Association may require the complaining homeowner to make the following preliminary dispute resolution efforts:

1. Make a written request to the offending owner requesting correction of the problem.
2. Demonstrate to the board that a good faith attempt was made to resolve the problem prior to making a request to the association.
3. Document the conditions of the problem and what you wish to be corrected. Documentation should include, but not be limited to, the following:
  - a. Photographs (if applicable)
  - b. Description of affected area (be specific)
  - c. Date and time of complaint
  - d. Source of the cause of concern
  - e. Is the problem ongoing?
  - f. Copy of the correspondence from item #1
4. The complaining homeowner may request assistance by requesting a hearing appointment. The submittal of a request for association involvement does not guarantee a board decision to intervene. Some matters may not be appropriate for the association to take enforcement action. If your issue involves the violation of city or county ordinances or building codes, etc., you may be instructed to contact the city or county, respectively, for enforcement of such ordinances or building codes, etc.
5. Should the issue remain unresolved after the foregoing procedures; the board will determine whether to forward the information to the association's attorney for further action, which may include coordinating alternative dispute resolution (ADR) proceedings with an arbitrator or mediator or filing a lawsuit.

NOTE: All legal costs, including attorney fees and filing fees, may be charged to the owner who is found to be at fault and / or split between the neighbors in dispute.

### DRAINAGE POLICY PROCEDURE

Area drains must be installed in private yards for adequate drainage to permit the plants to survive and to minimize the ponding of water. There shall be no interference with the established drainage patterns over any lot, or Common Area, unless an adequate alternative provision is made for proper drainage and is first approved in writing by the DRC. The landscape irrigation system should be designed to prevent excessive saturation of soils. Planters created by walkways next to a residence should be a **minimum of 6" below weep screed** and drain away from house surface and should contain drain inlets to drain excess water.

The following actions shall be requested of a homeowner by the Board of Directors if water is draining to an adjacent resident's lot.

#### Drainage Occurring from Private Property

1. The complaining homeowner shall speak directly with the offending property owner. If other action is necessary, then:

A letter shall be sent from the complaining homeowner to the offending homeowner by certified mail, requesting resolution to the issue.

If other action is necessary, then:

2. The complaining homeowner shall present the letter sent to the offending homeowner with the mail receipt to the Board of Directors to show that the above actions were completed, and the issue remains unresolved. The Board of Directors shall, at their discretion, recommend that the complaining homeowner obtain a written opinion from a registered civil engineer (R.C.E.) at the cost of the complaining homeowner. If the written opinion supports the allegations against the offending homeowner, the board shall, again at their discretion, send a letter, with the written opinion attached to the offending homeowner by certified mail, requesting resolution to the issue.

If other action is necessary, then:

3. The board shall, at their discretion, refer the issue back to the complaining and offending homeowners to resolve themselves, as to who will pay for the civil engineering opinion and correct the drainage issue. If the board refers the issue back to the homeowners, a written confirmation of this will be mailed to each homeowner.

NOTE: When the above conditions are satisfied with the support of the complaining party and the evidence provided, the board, at their discretion, may consider taking action, including possible referral of the matter to the TMC attorney for the necessary steps to attempt to have the drainage problem alleviated.

All legal costs, including attorney fees and filing fees, will then be charged to the owner who is causing the water damage.

Drainage Occurring from Common Property

1. The complaining homeowner shall present to the Board of Directors information describing the drainage issue. The board shall, at their discretion, request that the complaining homeowner obtain a written opinion from a registered civil engineer (R.C.E.) at the cost of the complaining homeowner. The report shall state the engineer's opinion, and one or more recommended solutions.
2. The complaining homeowner shall submit the written opinion to the board for their review.
3. If the written opinion supports the complaining homeowner's allegations against the Association, the Board shall, at their discretion, pay to correct the drainage issue, and reimburse the homeowner for the amount paid to obtain the written opinion of a registered civil engineer.
4. If the written opinion does not support the complaining homeowner's allegations, the Board of Directors shall, at their discretion, take no further action on the issue.

**ADDITION TO TALEGA MAINTENANCE CORPORATION  
ARCHITECTURAL GUIDELINES**

**SPECIAL REQUIREMENTS FOR THE SUBMITTAL OF  
ARCHITECTURAL PLANS AND THE INSTALLATION OF  
LANDSCAPE AND HARDSCAPE IMPROVEMENTS FOR**

**TRINIDAD AND CARMEL AT TALEGA**

As detailed in the Architectural Guidelines and CC&Rs for Trinidad at Talega and Carmel at Talega, there is a Talega Maintenance Corporation (TMC) maintained drain line which runs through the rear yard of the properties within these two Sub Associations. TMC has an easement over the area where the line has been installed to allow for maintenance and repair. Information received at the close of escrow depicts the exact location of the drain line and easement.

The below detailed guidelines must be followed when planning the installation of improvements in the rear yards of homes at Trinidad and Carmel. These requirements will help ensure that the integrity of the drain lines is protected and that the line is easily accessible for any necessary maintenance. Thank you for your cooperation.

- 1) All plans must clearly depict the location of the drain line and the related easement.
- 2) No trees are to be planted in the easement area. Trees planted within 3' of the easement area will be required to have a root barrier installed. Small bushes and flowers without extensive deep root systems are allowed.
- 3) Hardscape sidewalks and patios may be installed over the area. However, in the event the Talega Maintenance Corporation (TMC) needs to do repair work to the mainline, the TMC will not be responsible for any damage or obligated to restore the hardscape improvements. The TMC will restore grass cover only.
- 4) The homeowner may only connect their individual yard drain system to the connection point provided. The existing drain lines cannot be moved or altered in any manner, nor can an owner tie into the mainline at any other location.
- 5) Raised planters or decorative walls which require footings may not be installed in the easement area. Aboveground planters may be acceptable, but all footings are prohibited.

**ADDITION TO TALEGA MAINTENANCE CORPORATION  
ARCHITECTURAL GUIDELINES**

**SPECIAL REQUIREMENTS FOR THE SUBMITTAL OF  
ARCHITECTURAL PLANS AND THE INSTALLATION OF  
LANDSCAPE AND HARDSCAPE IMPROVEMENTS FOR**

**VERANO AT TALEGA**

As detailed in the Architectural Guidelines and CC&Rs for Trinidad at Verano at Talega, there is a Talega Maintenance Corporation (TMC) maintained drain line which runs through the rear yard of the properties within the Sub-Associations. TMC has an easement over the area where the line has been installed to allow for maintenance and repair. Information received at the close of escrow depicts the exact location of the drain line and easement.

The below detailed guidelines must be followed when planning the installation of improvements in the rear yard of homes at Verano. These requirements will help ensure that the integrity of the drain lines is protected and that the line is easily accessible for any necessary maintenance. Thank you for your cooperation.

1. The grading and drainage design in the neighborhood should not be altered while installing Improvements in a manner that will redirect surface water flow toward the Residences or onto adjacent property or that will trap water so that it ponds or floods. Drainage devices such as concrete ditches, area drain lines and gutters should be carefully designed and installed with professional assistance then maintained in an unobstructed condition. Drainage devices installed by the declarant designed to serve more than one condominium or the Common Area should not be altered in a manner that will redirect or obstruct the drainage through these drainage devices. Grading and drainage modifications are subject to law, approval by the Board, and the terms of any drainage easements of Record.
2. Additional drainage shall tie into existing drainage. All improvements are to slope towards drains and drains are to be mounted flush with improvements. Improvements may settle over time and the level of drains must be adjusted accordingly.
3. Pools, Spas & Hot Tubs: Due to noise, privacy, maintenance and drainage issues, no pools, spas, or hot tubs can be approved by the DRC as the association is a condominium development.
4. Outdoor patio or lounge furniture, plants and barbecue equipment may be kept in Exclusive Use Areas pursuant to the Rules and Regulations.
5. No portable sports equipment, such as basketball standards, soccer nets and the like, may be used in alleys or in streets, driveways or sidewalks.

6. Plot Plan: Show exclusive use patio area lines accurately as to length, angles and amount of curve. Show all existing and proposed buildings, structures, fences, walls, sidewalks, drain lines and other Improvements; indicate all required setbacks. Show all dimensions on work to be considered, distances between existing and proposed work and distances between proposed work and boundaries of exclusive use patio area.
7. When proposed improvements involve changing existing grades by more than 1.00' foot or changing existing drainage, show contours or spot elevations, flow lines, finish grades and proposed drainage systems. Drawings for proposed improvements requiring a change to existing drainage shall be prepared by a registered civil engineer or licensed landscape architect. All proposed Improvements shall maintain drainage on homeowner's lot.
8. Landscape Plan: (may be included as part of Plot Plan) Include proposed hardscape, planting areas and plant names, trellises (freestanding wooden fixtures painted to match trim or the color of the exterior structure and must be consistent with the appearance of the building), arbors (freestanding wooden fixtures painted to match trim or the color of the exterior stucco and must be consistent with the appearance of the building.), ornamental rocks, barbecues, play equipment, apparatus and yard lighting. Call out all easements on or over property. There is to be no attachment of trellis, shade structure, arbor or any similar device to the building.
9. All trees should be planted no closer than five 5' feet from any building, fence or sidewalk.
10. All trees shall be planted with root barriers, twenty-four (24") inches deep.
11. Any tree with a large canopy at maturity must be in the yard so that the mature canopy does not encroach into neighboring yards or Common Area.

**ADDITION TO TALEGA MAINTENANCE CORPORATION  
ARCHITECTURAL GUIDELINES  
SPECIAL REQUIREMENTS FOR THE SUBMITTAL OF  
ARCHITECTURAL PLANS AND THE INSTALLATION OF  
LANDSCAPE AND HARDSCAPE IMPROVEMENTS FOR**

**TALEGA GALLERY**

As detailed in the Supplemental Declaration of the CC&Rs for Talega Gallery at Talega, Talega Maintenance Corporation (TMC) has a nonexclusive easement over designated Lots as depicted in Exhibit E as depicted in Exhibit D or Exhibit C for each applicable Phase and Tract No. for access reasonably necessary in connection with maintenance of the slope, the Verdura Wall and the Geogrid located on said Lot.

**Slope Reinforcement:**

Certain slopes in the Residential Area are reinforced with retaining walls and / or below-grade liners. Owners of the lots or condominiums in the Residential Area that are improved with or adjacent to these slopes are subject to the following restrictions:

1. Verdura Retaining Walls. Certain slopes in the Residential Area are reinforced with a Verdura Retaining Wall ("Verdura Wall"). A Verdura Wall is a modular concrete retaining wall system. Once installed, it is intended to remain in place indefinitely. TMC will be responsible for the maintenance and repair of the Verdura Walls in the Residential area. Owners of residential lots or condominiums improved with the Verdura Walls may NOT modify the Verdura Wall nor construct Improvements nor undertake any excavation or other work which will interfere with the integrity of the Verdura Wall.
2. Geogrid Fabric. Certain slopes in the Residential Area are reinforced with Geogrid, which is a synthetic fabric installed on the slope and in residential lots, condominiums or Common Area lying at the top of the slope. Geogrid is buried below the surface, and it is intended to remain in place indefinitely. Owners of Lots improved with Geogrid understand that excavation may damage the Geogrid and affect the stability of the slope. Therefore, before performing any excavation in the rear yard, each Owner must consult a soil engineer and obtain written consent of the TMC Board of Directors.

According to Supplemental Declaration of the CC&Rs for Talega Gallery at Talega, these Lots also have a Verdura Wall within the Residential Area and the Geogrid fabric (Exhibit "A-2" Property Walls): Tract No. 15967 Lot 7; Lots 114 and 115; Tract No. 15921 Lots 1, 2, 3, 4, 5, and 6.

The following exhibits (Exhibit E, Exhibit D or Exhibit C, per Phase and Tract No.) indicate the Lots which have a Verdura Wall within the Residential Area and the approximate location of the Geogrid fabric. Please contact Management for more information on the above Exhibits.

## EXHIBIT D-1

TALEGA PLANT PALETTE

The following lists are recommended plant materials for landscaping throughout Talega. The list contains plants which may be used within a neighborhood and private yards. Other plant species and cultivars of the trees and plant materials will be reviewed on a case-by-case basis.

\* INDICATES DROUGHT TOLERANT PLANTS

TREESCommon NameBotanical Name

* Afghan Pine	Pinus eldarica
* Brisbane Box	Tristania conferta
* Bronze Loquat	Eriobotrya deflexa / japonica
* Bushy Yate	Eucalyptus lehmannii
* California Pepper	Schinus molle
* California Sycamore	Platanus racemosa
* Carolina Laurel Cherry	Prunus caroliniana
Citrus	Citrus species
* Chitalpa	Chitalpa tashkentensis
* Coast Live Oak	Quercus agrifolia
* Coral Gum	Eucalyptus torquata
* Coral Tree	Erythrina caffra / sykeski / coralloides
* Crape Myrtle	Lagerstroemia X faureri
* Desert Willow	Chilopsis linearis
* Fern Pine	Podocarpus gracilior / henkelii
* Floss Silk Tree	Chorisia speciosa
* Giant Dracaena	Cordyline australis / indivisa
* Gimlet	Eucalyptus salubris
*Guadalupe Palm	Brahea edulis
* Holly Oak	Quercus ilex
Jacaranda	Jacaranda mimosifolia "acutifolia"
Japanese Maple	Acer palmatum
King Palm	Archontophoenix cunninghamiana
* Laurel Box	Tristania laurina
Magnolia Little Gem	Magnolia g. 'Little Gem'
* Mediterranean Fan Palm	Chamaerops humilis / C. h. cerifera
Melaleuca	Melaleuca nesophila / quinquinervia
Mondell Pine	Pinus eldarica
New Zealand Christmas Tree	Metrosideros excelsa
* Olive	Olea europaea / Swan Hill (Fruitless) /Skylark dwarf
* Peppermint Tree	Agonis flexuosa
* Pineapple Guava	Feijoa sellowiana
Pigmy Date Palm	Phoenix roebelenii
Primrose or Cow-itch Tree	Lagunaria patersonii

## EXHIBIT D-2

**TREES****Common Name**

Rusty Leaf Fig  
 Senegal Palm  
 \* Stone Pine  
 \* Strawberry Tree  
 \* Sweet Bay  
 \* Torrey Pine  
 \* Toyon  
 \* White Ironbark  
 \* Willow-Leafed Peppermint  
 \* Windmill Palm  
 \* Victorian Box

**Botanical Name**

Ficus rubiginosa  
 Phoenix reclinata  
 Pinus pinea  
 Arbutus unedo compacta7 andrachne / marina  
 Laurel noblis  
 Pinus torreyana  
 Heteromeles arbutifolia  
 Eucalyptus leucoxylon  
 Eucalyptus nicholii  
 Trachycarpus fortunei  
 Pittosporum tobira / undulatum

**SHRUBS****Common Name**

\* Agave  
 \* Baja Fairy Duster  
 \* Baja Rose  
 \* Bird of Paradise  
 \* Blue Hibiscus  
 \* Bougainvillea  
 \* Brazilian Flame Bush, Trinidad Flame Bush  
 \* Bush Poppy  
 \* California Encelia  
 \* California Fushia  
 \* California Tree Mallow  
 \* Cape Honeysuckle  
 \* Cape Rush  
 \* Catalina Cherry  
 \* Century Plant  
 \* Chaparral Mallow  
 \* Coastal Prickly Pear  
 \* Coast Rosemary  
 \* Coffeeberry  
 \* Compact Shiny Xylosma  
 \* Coral Aloe  
 \* Coral Bells  
 Creeping Coprosma  
 \* Creeping Mahonia  
 \* Daylily-Lady Eva, "Morning Cheerfulness", Lee Bee  
 Orange Crush, "Acapulco Night"  
 \* Deer Grass  
 \* Desert Broom  
 Dwarf Canna

**Botanical Name**

Agave attenuata / shawii  
 Calliandra californica  
 Rosa minutifolia  
 Strelitzia reginae  
 Alyogyne huegelii  
 Bougainvillea  
 Calliandra tweedii  
 Dendromecon rigida  
 Encelia californica  
 Epilobium californicum  
 Lavatera assurgentiflora  
 Tecomaria capensis  
 Chondropetlum tectorum  
 Prunus lyonii  
 Agave americana  
 Malocathamnus fasciculatus  
 Opuntia littoralis  
 Westringia Wynyabbie Gem  
 Rhamnus californica  
 Xylosma congestum 'compacta'  
 Aloe striata / arborescens  
 Heuchera hybridus  
 Coprosma kirkii / "Variegata" / "Verde Vista"  
 Mahonia repens  
 Hemerocallis hybrids  
 Muhlenbergia rigens  
 Baccharis sarothroides '  
 Canna 'pfitzers dwarf

## EXHIBIT D-3

**SHRUBS****Common Name****Botanical Name**

* Dwarf Coyote Brush	Baccharis pilularis
* Dwarf Mexican Bush Sage	Salvia leucantha "Santa Barbara"
* Escallonia	Escallonia fradesii
* Evergreen Currant	Ribes viburnifolium
* Fairy Duster, False Mesquite	Calliandra eriophylla
* Flannel Bush, 'El Dorado Gold'	Fremontodendron californicum
* Fraser Photinia	Photinia fraseri
* Fuchsia-Flowering Gooseberry	Ribes speciosa
* Golden Abundance	Mahonia "Golden Abundance"
'Howard McMinn'	Arctostaphylos "Howard McMinn"
* India Hawthorne	Raphiolepis indica
* Island Bush Snapdragon	Galvezia speciosa
* Juniper	Juniperus
* Lady Bank's Rose	Rosa banksiae
* Lantana	Lantana camara
* Lantana, Trailing	Lantana montevidensis
* Laurel Sumac	Rhus laurina "malosma laurina"
* Lavender	Lavandula species
* Lavender Starflower	Grewia occidentalis
* Lemonade Berry	Rhus integrifolia
Lily of the Nile	Agapanthus africanus
* Longleaf Mahonia	Mahonia nervosa
* Marigold	Tagetes lemmoni
* Monkey Flower	Mimulus aurantiacus
* Muhly Grass	Muhlenbergia lindheimeri "autumn glow"
* Natal Plum	Carissa "green carpet"
* Nevin Mahonia	Mahonia nevinii
* New Zealand Flax	Phormium tenax
* Oregon Grape	Mahonia aquifolium "compacta"
* Pacific Coast Iris	Iris douglasiana
* Pigeon Point, Twin Peaks	Baccharis "centennial"
* Pride of Madiera	Echium fastuosum
* Pink Muhly Grass	Muhlenbergia capillaris 'regal mist'
Pink Powder Puff	Calliandra haematocephala
Poverty Weed	Iva hayesiana
Powis Castle Sage	Artemisia "powis castle"
* Prostrate Acacia	Acacia redolens "Desert Carpet/ 'Low Boy'"
* Purple Hopseed Bush	Dodonaea viscosa "Purpurea"
* Red Autumn Sage	Salvia greggii
* Red/Purple Fountain Grass	Pennisetum setaceum "rubrum" ONLY
* Red Hot Poker	Kniphofia uvaria
* Red Yucca	Hesperaloe parviflora

## EXHIBIT D-4

**SHRUBS****Common Name**

\* Rockrose  
 \* Rose  
 \* Sea Lavender  
 \* Silverberry  
 \* Silver Sheen  
 \* Society Garlic  
 \* Stern Thompson  
 \* Sugar Bush  
 \* Tobira  
 \* True Myrtle  
 Viburnum Suspensum  
 \* Wild Lilac  
 Yaupon

**Botanical Name**

Cistus  
 Rosa sp. "Don Juan"  
 Limonium perezii  
 Elaeagnus pungens  
 Pittosporum tenuifolium  
 Tulbaghia violacea  
 Baccharis "thompson"  
 Rhus ovata  
 Pittosporum tobira / variegata  
 Myrtus communis  
 Sandankwa viburnum  
 Ceanothus spp.  
 Ilex vomitoria

**GROUND COVER /BORDERS****Common Name**

\* Beach Evening Primrose  
 \* Bearberry  
 \* Bearberry  
 \* Blue-Eyed Grass  
 \* Blue Fescue  
 \* California Wild Grape  
 \* Catalina Island Live-Forever  
 \* Carpet Manzanita  
 \* Coral Bells Hybrid  
 \* Creeping Coprosma  
 \* Dwarf Mock Orange  
 \* Fairy Fan Flower  
 \* Hens & Chickens  
 \* Indian Mallow  
 \* Kleinia  
 \* Myoporum  
 \* Myoporum, Pacific  
 \* Ornamental Strawberry  
 \* Pacific Mist Manzanita  
 \* Prostrate Rosemary  
 \* Red Buckwheat  
 \* Rockrose  
 \* Sage  
 \* Santa Barbara Daisy  
 \* Scarlet Coyote Mint

**Botanical Name**

Camissonia cheiranth  
 Arctostaphylos uva-ursi  
 Cotoneaster dammeri  
 Sisyrinchium bellum  
 Festuca ovina glauca  
 Vitis californica  
 Dudleya hassei  
 Arctostaphylos "Emerald Carpet"  
 Heuchera hybrids  
 Coprosma kirkii  
 Pittosporum "Wheeler's Dwarf" / "Crème de Mint"  
 Scaveola "New Wonder"  
 Echeveria imbricate  
 Abutilon palmeri  
 Senecio mandraliscae  
 Myoporum parvifolia  
 Myoporum pacificum Myoporum, Pacific  
 Fragaria chiloensis "California"  
 Arctostaphylos 'pacific mist'  
 Rosmarinus officianalis 'prostratus' / Irene  
 Eriogonum grande rubescens  
 Cistus species  
 Salvia species  
 Erigeron karvinskianus  
 Monardella macrantha

EXHIBIT D-5

**GROUND COVER / BORDERS**

**Common Name**

**Botanical Name**

- \* Silver Carpet
- \* Star Jasmine
- \* Society Garlic
- \* Stonecrop
- \* Succulent - ncn
- \* Trailing Acacia
- \* Verbena

- Dymondia margaretae
- Trachelospermum jasminoides
- Tulbaghia violacea
- Sedum species
- Apentia cordifolia
- Acacia redolens
- Verbena species

**VINES/ESPALIERS:**

**Common Name**

**Botanical Name**

- \* Bougainvillea
- \* Bower Vine
- Climbing Rose
- Creeping Fig
- \* Japanese Wisteria
- \* Jasmine
- Lavender Star Flower
- Madagascar Jasmine
- Pink Powder Puff
- Red Trumpet Vine
- Star Jasmine
- \* Violet Trumpet Vine

- Bougainvillea species
- Pandorea jasminoides
- Rosa varieties
- Ficus pumila
- Wisteria floribunda Asminium species
- Grewia occidentalis Stephanotis floribunda Calliandra haematocephala Distictus buccinatoria trachelospermum
- Jasminoide lytostoma callistegioides

**RESTRICTIONS**

Use of certain trees may be restricted in their use due to the proposed location on the property. Although trees may be listed as recommended in these Guidelines, each Applicant has the responsibility of selecting trees appropriately scaled for the intended location. The homeowner is responsible for ensuring that no trees are planted too close to any structure which may cause potential damage to that structure or infrastructure such as sidewalks and drain lines. All proposed trees along property lines should be setback a minimum of 5 feet, measured from the trunk to the inside of the property line wall, or far enough to prevent tree canopy, at maturity, from extending into neighboring yards or over community sidewalks. All trees shall be planted with root barriers, 24" deep.

**Calif. Sycamore, Ficus, Coral Tree, etc.** - known to have invasive root systems are not to be planted near property line or community walls where damage could potentially occur. Ample space shall be provided for trees with large root and canopy systems.

**Giant Bird of Paradise Trees, etc.** — Not to be planted in side yards immediately adjacent to property line walls / fences.

## EXHIBIT D-6

**Creating Visual Barriers or Privacy Screens Are Not Permitted**

Any plant material, including trees and shrubs, planted to create a visual barrier / privacy screen will be reviewed by the DRC on a case-by-case basis. The use of more than three (3) Italian Cypress "Cupressus sempervirens" or other similar plants in a row to create barriers / screens is not permitted unless reviewed and approved by the DRC on a case-by-case basis.

**LIST OF INVASIVE AND UNDESIRABLE PLANT AND TREE SPECIES "NOT ALLOWED" ON PRIVATE RESIDENTIAL LOTS:**

<u>Common Name</u>	<u>Botanical Name</u>
American Elm	Ulmus americana
Bamboo	All species; Running and Clumping
Banana	Musa; all species
<b>Bermuda</b> Grass	Cynodon dactylon
<b>Blue</b> Gum Tree	Eucalyptus globulus
Brazilian Pepper Tree	Schinus terebinthifolius
Bridal Creeper	Asparagus asparagoides
Bromus Rebens	Foxtail Brome; all Bromus species
Camphor Trees	Cinnamomum camphora
Cap Ivy	Delairea odorata
Ficus	All Ficus species (Except 'Ficus Rubiginosa')
European White Birch	Betula pendula
Follopia	Follopia species
Fountain Grass	Pennisetum Species (Except Pennisetum `rubrum')
Giant Reed	Arundo donax
German Ivy	Senecio mikanioides
Horsetail Bamboo	Equisetum hyemale; all species
Ivy	Hedera
Ice Plant	Carpobrotus species
Mexican Feather Grass	Nassella / Stipa all species
Pampas Grass	Cortaderia hubata
Periwinkle	Vinca major
Passion Vine	Passifloraceae species
Papyrus	Cyperus: all species
Rough Horsetail or Scouring Rush	Equisetum hyemale
Tamarisk	Tamarix species
Slender Wild Oat	Avena barbata
St. Augustine Grass	Stenotaphrum secundatum

## EXHIBIT D-7

## PLANTS RECOMMENDED FOR FUEL MODIFICATION ZONES

**TREES****Common Name**

- \* California Sycamore
- \* Coast Live Oak

**Botanical Name**

Platanus racemosa  
Quercus agrifolia

**SHRUBS****Common Name**

- \* Acacia "Desert Carpet"
- \* Bladder Sage
- \* California Lilac
- \* Coffeeberry

**Botanical Name**

Trailing acacia  
Salazaria mexicana  
Ceanothus spp.  
Rhamnus californica

**SHRUBS****Common Name**

- \* Coyote Bush
- \* Currant
- \* Dwarf Coyote Brush
- \* Deerweed
- \* Lantana, Trailing
- \* Lemonade Berry
- \* Monkey Flower
- \* Myoporum
- \* Oregon Grape
- \* Pacific Coast Iris
- \* Pacific Mist Manzanita

**Botanical Name**

Baccharis "Thompson"  
Ribes species  
Baccharis "Pilularis"  
Lotus scoparius  
Lantana montevidensis  
Rhus integrifolia  
Mimulus species  
Myoporum species  
Mahonia "Golden Abundance"  
Iris douglasiana  
Archtopstaphylos "Pacific Mist"

**GROUND COVERS****Common Name**

- \*Pink Hibiscus
- Prickly Pear
- \*Purple Needlegrass
- Rockrose
- \*Strawberry Tree, Compact
- \*Toyon
- Wild Lilac

**Botanical Name**

Anisodonte "Tara's Choice"  
Opuntia littorals / leptocaulis  
Stipa pulchra  
Citrus species  
Arbutus unedo "Compacta"  
Heteromeles arbutifolia  
Ceanothus species

## SETBACK FOR OUTDOOR FIREPLACES

Outdoor fireplaces, fire pits, or other similar items must be setback from any property line, perimeter fence/wall and/or top of slope a minimum of 5 feet and must be natural or propane gas burning only. If the proposed structure is higher than the adjacent wall or fence, a setback equal to or greater than the height of the structure is required, whichever is more restrictive. Maximum height shall not exceed 13' (including spark arrestor) measured from original pad elevation. For example, an 11' high fireplace must be set back 11' minimum from both rear and side property lines. Structure must be screened with evergreen plant material.

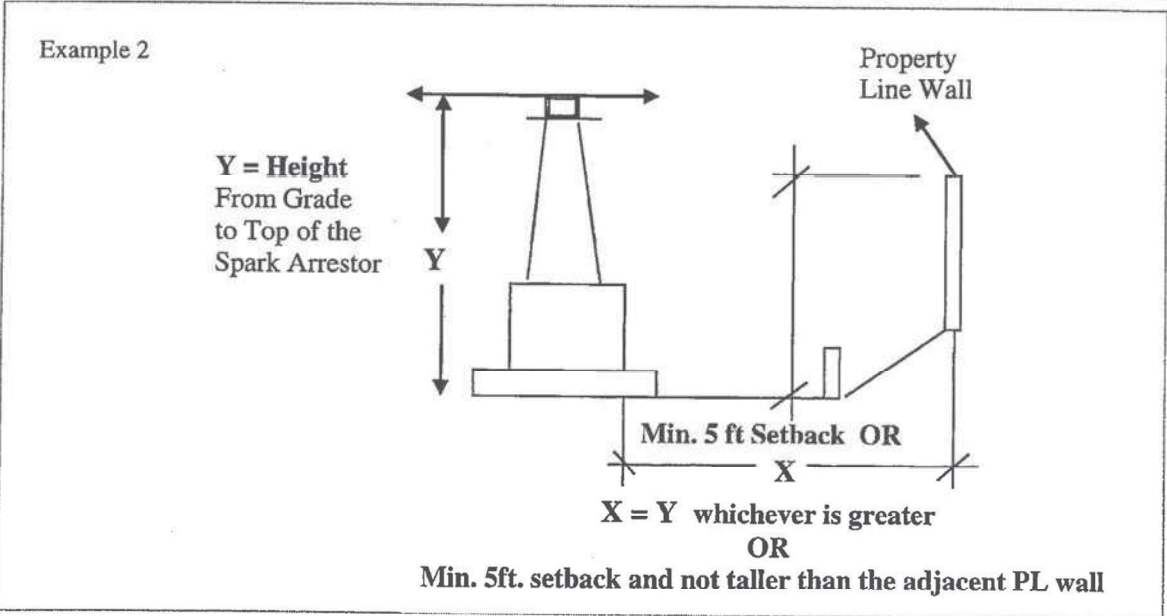
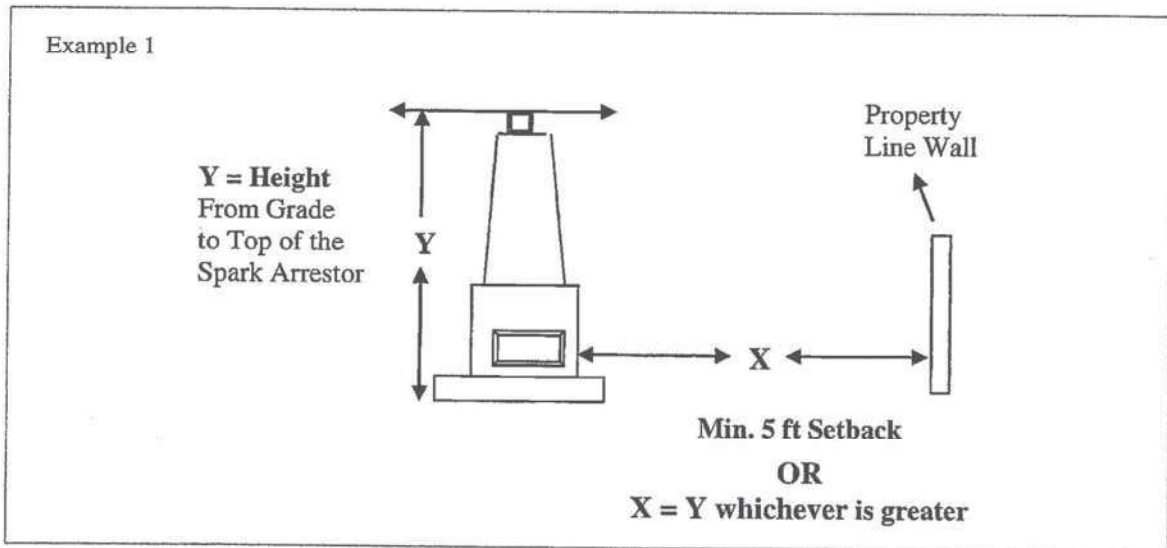

**EXHIBIT E-6**

**SAMPLE PLANTING PLAN**

- Use symbols or numbers to represent individual plants, drawn to approximate spread at maturity. Plans should show complete coverage of areas to be landscaped.
- Include a legend with both botanical and common names.

Sample planting plan

EXHIBIT F

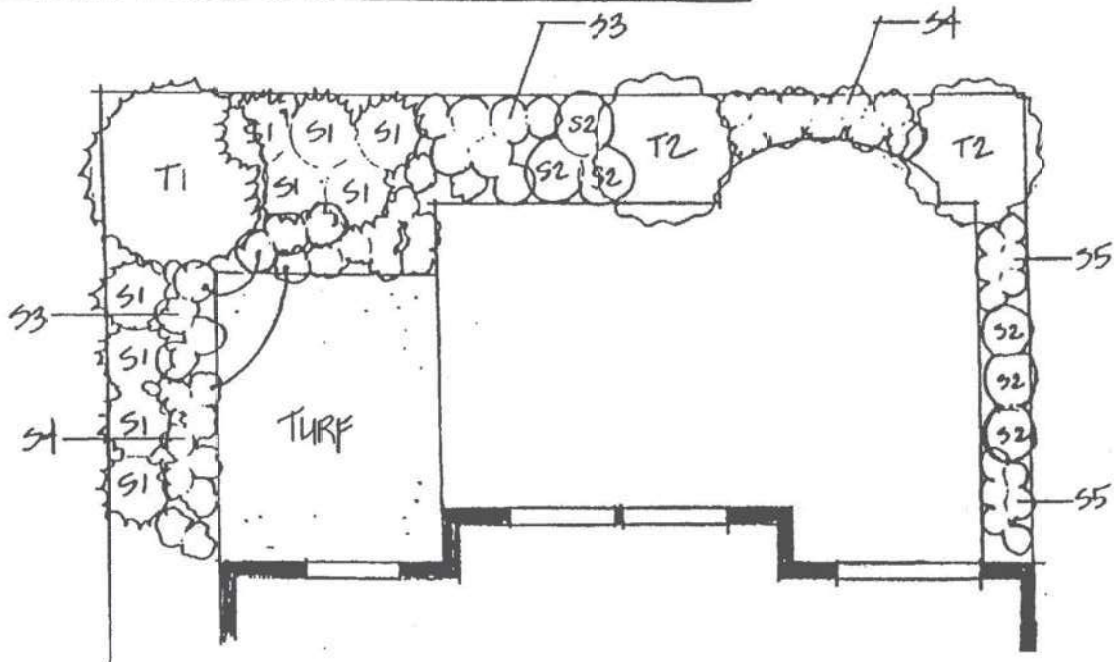

PLANTING LEGEND

SYM.	BOTANICAL NAME	COMMON NAME	SIZE	QTY.
T1	ACONIS FLEXUOSA	PEPPERMINT TREE	36" BOX	1
T2	FEUOA SELLOWIANA	PINEAPPLE GUAVA	24" BOX	2
S1	PHIPMILUM TENAX	NEW ZEALAND FLAX	5 GAL	9



ELEVATION - TYPICAL WALL PROFILE WITH GRADE CHANGE  
SCALE: NTS

NO STEP CONDITIONS SHALL EXIST.  
CONTRACTOR TO CUT BLOCK TO  
SLOPE WALL WITH GRADE THEN  
ADD CAP.

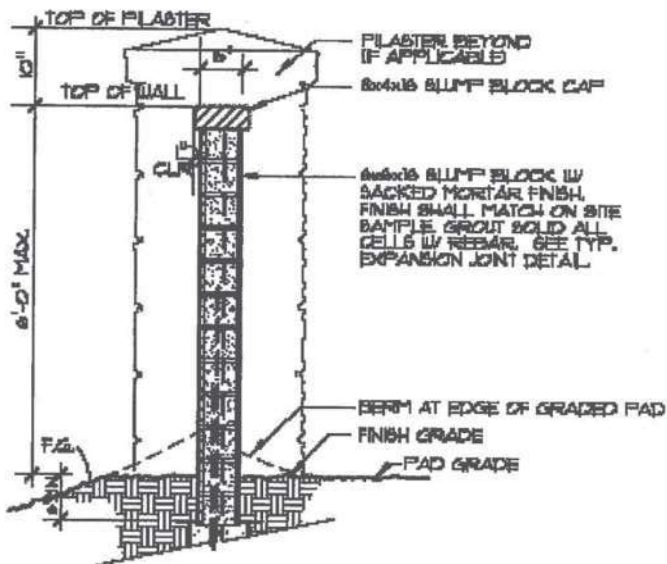

TALEGA STONE AND CAPS  
AVAILABLE EXCLUSIVELY THROUGH  
VALLEY BUILDING MATERIALS  
2871 CHERRY AVENUE  
LAKE FOREST, CA. 92650  
CONTACT: JIM SINE  
(949) 358-0756

NOTE:  
PAINT SLUMP BLK. WALL WITH:  
VILLAGE 1 & 2 - (1) COAT FRAZEE 'EPOTILT' & (1) COAT  
FRAZEE 'ACRITEC' FRAZEE ARIZONA WHITE  
NO. 183  
VILLAGE 3, 4, 5 & 6 - (1) COAT BENJAMIN MOORE NO. HC-44

DETAIL PROVIDED FOR USE IN MATCHING  
COMMUNITY STANDARDS. STRUCTURAL & FOOTING  
DETAILS ARE THE RESPONSIBILITY OF HOMEOWNER  
OR HOMEOWNER'S CONTRACTOR (STRUCTURAL &  
FOOTING DETAILS DO NOT REQUIRE D.R.C. REVIEW.

6' SLUMP BLOCK WALL

N.T.S.

6' SLUMP BLOCK WALL  
EXHIBIT G-1

DETAIL PROVIDED FOR USE IN MATCHING COMMUNITY STANDARDS. STRUCTURAL & FOOTING DETAILS ARE THE RESPONSIBILITY OF HOMEOWNER OR HOMEOWNER'S CONTRACTOR (STRUCTURAL & FOOTING DETAILS DO NOT REQUIRE D.R.C. REVIEW).

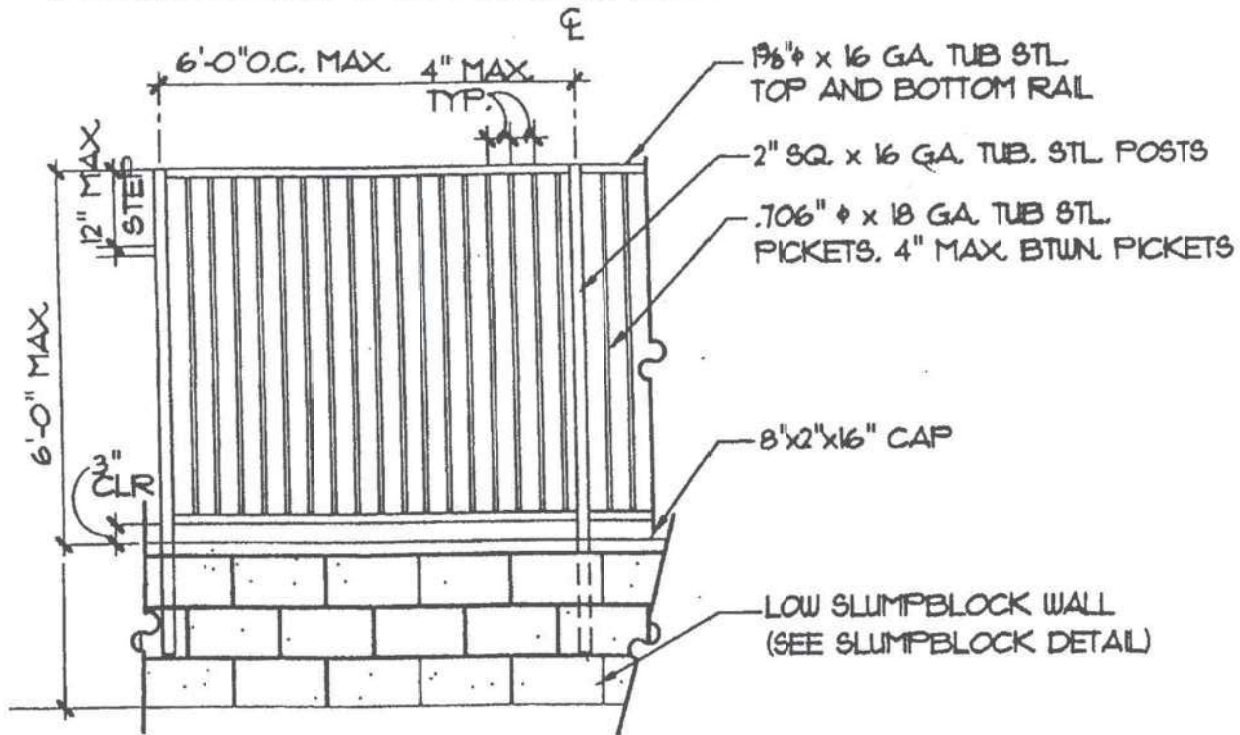

TUBULAR STEEL ATOP SLUMP BLOCK LOW WALL  
EXHIBIT G-2

TUBULAR STEEL ATOP SLUMPBLOCK LOW WALL  
N.T.S.

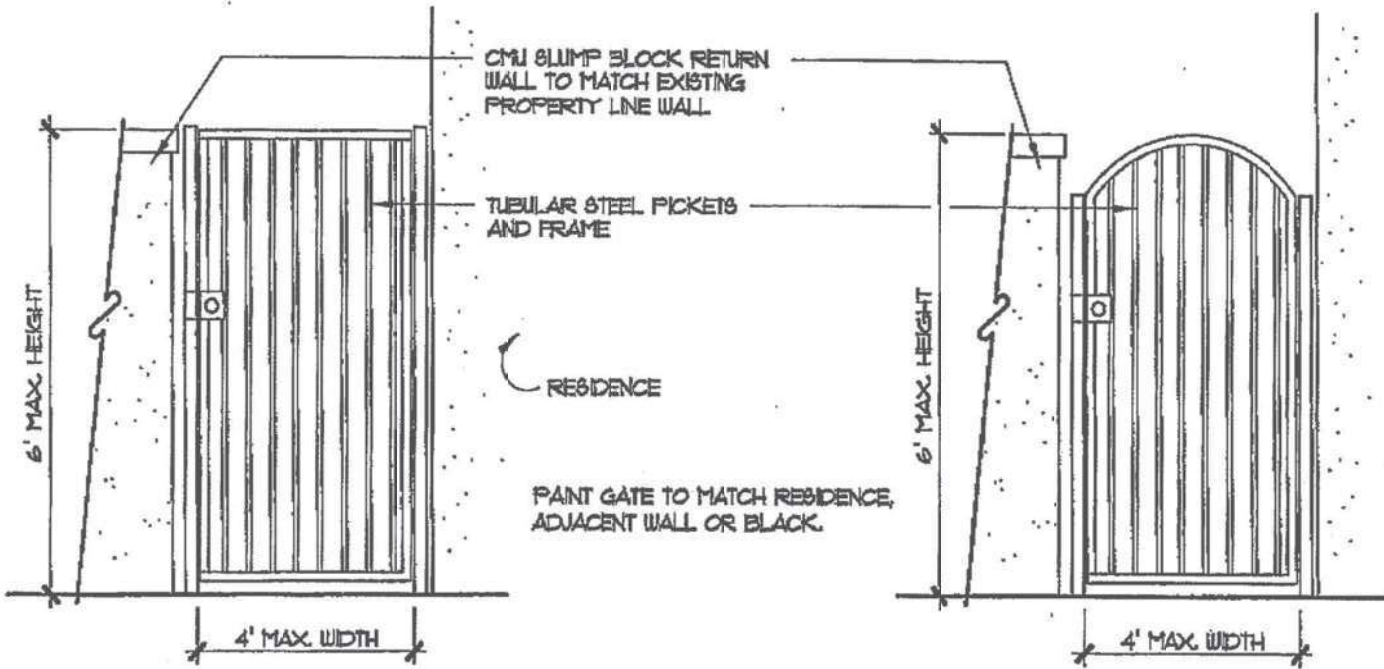

TUBULAR STEEL (WROUGHT IRON) GATE

TUBULAR STEEL (WROUGHT IRON) ARCHED GATE

# TALEGA D.R.C. APPROVED TUBULAR STEEL GATES

SCALE: 1/2" = 1'-0"

PRE-APPROVED TUBULAR STEEL GATE DETAIL

EXHIBIT G-3

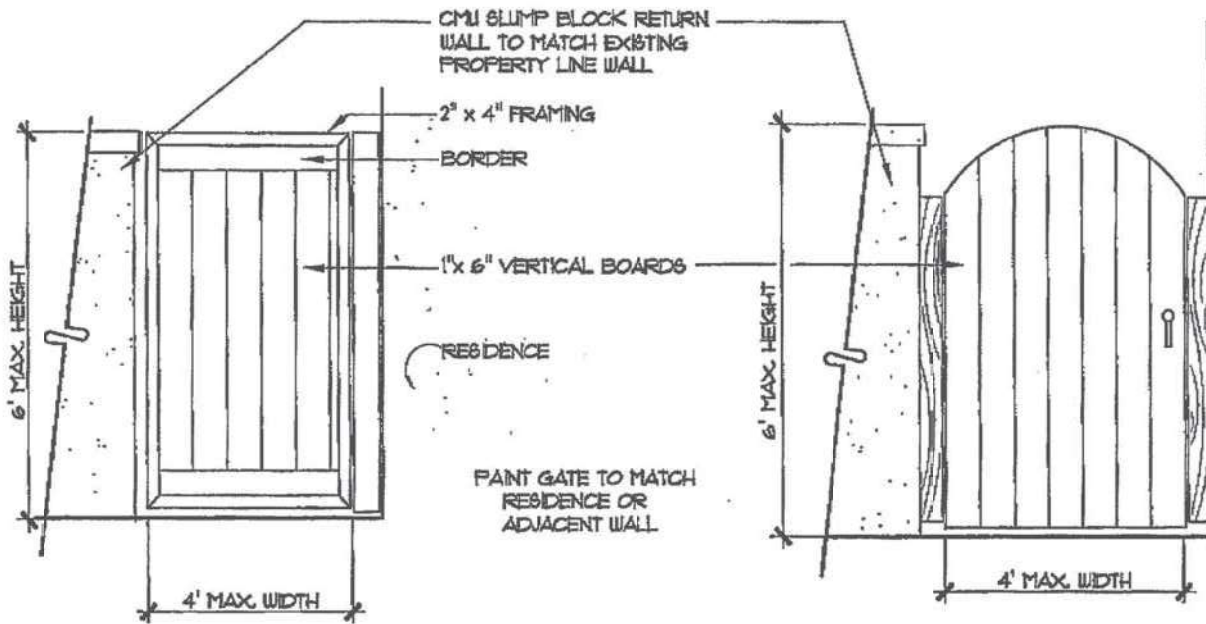

RECTANGULAR WOOD GATE

ARCHED WOOD GATE

# TALEGA D.R.C. APPROVED WOOD GATES

SCALE: 1/2" = 1'-0"

PRE-APPROVED WOOD GATE DETAIL  
EXHIBIT G-4